

Clamp-On Ground Resistance Tester Model 6418



CLAMP-ON GROUND TESTER



Copyright© Chauvin Arnoux®, Inc. d.b.a. AEMC® Instruments. All rights reserved.

No part of this documentation may be reproduced in any form or by any means (including electronic storage and retrieval or translation into any other language) without prior agreement and written consent from Chauvin Arnoux®, Inc., as governed by United States and International copyright laws.

Chauvin Arnoux®, Inc. d.b.a. AEMC® Instruments
15 Faraday Drive • Dover, NH 03820 USA
Tel: (800) 945-2362 or (603) 749-6434 • Fax: (603) 742-2346

This documentation is provided **as is**, without warranty of any kind, express, implied, or otherwise. Chauvin Arnoux®, Inc. has made every reasonable effort to ensure that this documentation is accurate; but does not warrant the accuracy or completeness of the text, graphics, or other information contained in this documentation. Chauvin Arnoux®, Inc. shall not be liable for any damages, special, indirect, incidental, or inconsequential; including (but not limited to) physical, emotional or monetary damages due to lost revenues or lost profits that may result from the use of this documentation, whether or not the user of the documentation has been advised of the possibility of such damages.

Statement of Compliance

Chauvin Arnoux[®], Inc. d.b.a. AEMC[®] Instruments certifies that this instrument has been calibrated using standards and instruments traceable to international standards.

We guarantee that at the time of shipping your instrument has met the instrument's published specifications.

An NIST traceable certificate may be requested at the time of purchase, or obtained by returning the instrument to our repair and calibration facility, for a nominal charge.

The recommended calibration interval for this instrument is 12 months and begins on the date of receipt by the customer. For recalibration, please use our calibration services. Refer to our repair and calibration section at www.aemc.com/calibration.

Serial #: _____

Catalog #: 2141.03

Model #: 6418

Please fill in the appropriate date as indicated:

Date Received: _____

Date Calibration Due: _____



Chauvin Arnoux[®], Inc.
d.b.a AEMC[®] Instruments
www.aemc.com

TABLE OF CONTENTS

1. INTRODUCTION.....	6
1.1 INTERNATIONAL ELECTRICAL SYMBOLS	6
1.2 DEFINITION OF MEASUREMENT CATEGORIES (CAT)	6
1.3 PRECAUTIONS FOR USE	7
1.4 RECEIVING YOUR SHIPMENT	8
1.5 ORDERING INFORMATION	8
1.5.1 Accessories and Replacement Parts	8
2. PRODUCT FEATURES	9
2.1 DESCRIPTION	9
2.2 FUNCTION KEYS	10
2.3 DISPLAY	10
2.4 INSERTING BATTERIES	11
2.5 DATE AND TIME SETUP	11
3. OPERATION	12
3.1 GENERAL	12
3.2 IMPEDANCE AND CURRENT MEASUREMENT	12
3.2.1 Connection	13
3.2.2 Freezing And/Or Storing A Measurement	13
3.2.3 Auto-Hold Function	14
3.2.4 Alarms	14
3.3 CURRENT MEASUREMENT	14
3.4 CONFIGURATION (SET-UP)	15
3.5 ERRORS	17
3.6 AUTOMATIC STOP	18
3.7 STORAGE	18
3.7.1 Recording A Measurement	18
3.7.2 Viewing Recordings	19
3.7.3 Erasing All Recordings	19
3.7.4 Memory Full	20
4. TECHNICAL CHARACTERISTICS	21
4.1 GENERAL REFERENCE CONDITIONS	21
4.2 ELECTRICAL CHARACTERISTICS	21
4.2.1 Impedance Measurements	21
4.2.2 Current Measurements	22
4.2.3 Storage	22









4.3 INFLUENCES	22
4.3.1 Impedance Measurement:	23
4.3.2 Current Measurement:	24
4.4 POWER SUPPLY	24
4.5 ENVIRONMENTAL CONDITIONS	25
4.6 MECHANICAL CHARACTERISTICS	25
4.7 COMPLIANCE WITH INTERNATIONAL STANDARDS	26
4.8 ELECTROMAGNETIC COMPATIBILITY (EMC)	26
5. MAINTENANCE	27
5.1 CLEANING	27
5.2 BATTERY REPLACEMENT	27
5.3 REPAIR AND CALIBRATION	29
5.4 TECHNICAL ASSISTANCE	29
5.5 LIMITED WARRANTY	30
5.5.1 WARRANTY REPAIRS	30

1. INTRODUCTION

Thank you for purchasing an AEMC® Instruments **Clamp-On Ground Resistance Tester Model 6418**.

For the best results from your instrument and for your safety, you must read the enclosed operating instructions carefully and comply with the precautions for use. Only qualified and trained operators should use this product.

1.1 INTERNATIONAL ELECTRICAL SYMBOLS

	Signifies that the instrument is protected by double or reinforced insulation
	CAUTION - Risk of Danger! Indicates a WARNING . Whenever this symbol is present, the operator must refer to the user manual before operation
	Indicates a risk of electric shock. The voltage at the parts marked with this symbol may be dangerous
	Application or withdrawal authorized on conductors carrying dangerous voltages. Type A current sensor as per IEC 61010-2-032
	Indicates Important information to acknowledge
	This product complies with the Low Voltage & Electromagnetic Compatibility European directives
	The product has been declared recyclable
	In the European Union, this product is subject to a separate collection system for recycling electrical and electronic components in accordance with directive WEEE 2012/19/EU

1.2 DEFINITION OF MEASUREMENT CATEGORIES (CAT)

- CAT IV:** Corresponds to measurements performed at the primary electrical supply (< 1000 V).
Example: primary overcurrent protection devices, ripple control units, and meters.
- CAT III:** Corresponds to measurements performed in the building installation at the distribution level.
Example: hardwired equipment in fixed installation and circuit breakers.
- CAT II:** Corresponds to measurements performed on circuits directly connected to the electrical distribution system.
Example: measurements on household appliances and portable tools.

1.3 PRECAUTIONS FOR USE

This instrument is compliant with safety standard IEC 61010-2-032, for voltages up to 100 V in CAT IV or 150 V in CAT III. Failure to observe the safety instructions may result in electric shock, fire, explosion, and destruction of the instrument and of the installations.

- The operator and/or the responsible authority must carefully read and clearly understand the various precautions to be taken in use. The operator and/or the responsible authority must carefully read and clearly understand the various precautions to be taken in use. Sound knowledge and a keen awareness of electrical hazards are essential when using this instrument.
- If you use this instrument other than as specified, the protection it provides may be compromised, thereby endangering you.
- The safety of any system in which this instrument might be incorporated is the responsibility of the integrator of the system.
- Do not use the clamp above its rated frequency, since this might cause it to overheat dangerously.
- Do not use the instrument on networks of which the voltage or category exceeds those mentioned.
- Observe the environmental conditions of use.
- Do not use the instrument if it seems to be damaged, incomplete, or poorly closed.
- Before each use, check the condition of the insulation on the housing. Any item of which the insulation is deteriorated (even partially) must be set aside for repair or scrapping.
- Before using your instrument, check that it is perfectly dry. If it is wet, it must be thoroughly dried before it can be connected or used.
- When handling the instrument, keep your fingers behind the physical guard.
- Avoid impacts on the measurement head, in particular the air gap.
- Keep the surfaces of the air gap clean; even a little dirt can cause the clamp to malfunction.
- Use personal protection equipment systematically.
- All troubleshooting and metrological checks must be done by competent accredited personnel.

1.4 RECEIVING YOUR SHIPMENT

Upon receiving your shipment, make sure that the contents are consistent with the packing list. Notify your distributor of any missing items. If the equipment appears to be damaged, file a claim immediately with the carrier and notify your distributor at once with a detailed description of any damage. Save the damaged packing container to substantiate your claim.

1.5 ORDERING INFORMATION

Clamp-On Ground Resistance Tester Model 6418 Cat. #2141.03
Includes hard carrying case, 5 Ω calibration loop, four 1.5 V AA batteries, wrist strap, Bluetooth adapter, multilingual safety sheet, Quick Start Guide, and USB drive containing User Manual.

1.5.1 Accessories and Replacement Parts

Hard Carrying Case **Cat. #2141.52**
5 Ω Calibration Loop **Cat. #2141.51**

<p>Order Accessories and Replacement Parts Directly Online Check our Storefront at www.aemc.com/store for availability</p>

2. PRODUCT FEATURES

2.1 DESCRIPTION

The simple-to-use Clamp-On Ground Tester Model 6418 makes ground impedance measurements in a parallel earth network, such as power distribution poles and overhead ground conductors. These measurements are simpler to perform than traditional measurements with two auxiliary rods.

The Model 6418 can make accurate low value ground impedances measurements and AC current measurements. The instrument's large oblong measurement head can clamp around bars up to 1.18 x 1.57 in (30 x 40 mm). The memory function records measurements for later viewing. Also, the instrument's OLED (Organic Light Emitting Diode) display screen is easy to read, even in direct sunlight.

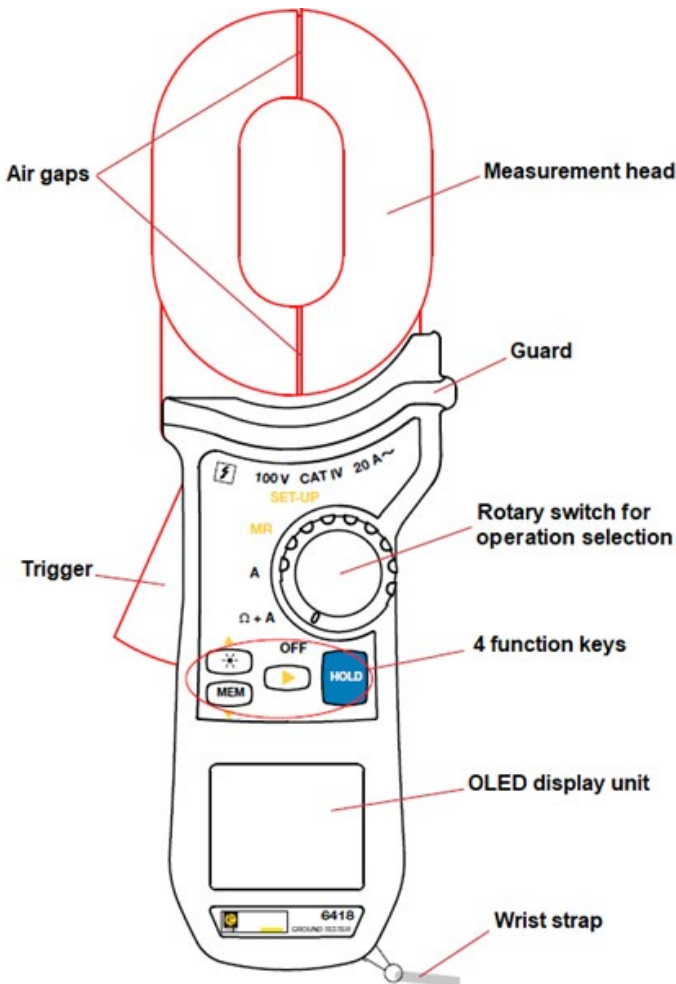

2.2 FUNCTION KEYS

As a general rule, functions shown in white on the keys are available when the switch is set to **Ω+A** or **A**. The yellow arrow keys (**▲**, **▼** and **▶**) are available when the switch is set to **MR** or **SET-UP**.

Key	Function
	Switch the display unit backlighting ON and OFF.
MEM	Record the measurement displayed.
HOLD	Freeze/unfreeze the display of the measurement.
▲ ▼	Browse in: <ul style="list-style-type: none"> ▪ SET-UP menu and change the value of the parameter selected. ▪ Memory read (MR).
▶	When switch is set to: <ul style="list-style-type: none"> ▪ Ω+A or A: a long press on ▶ activates/deactivates the audible signal. ▪ SET-UP: ▶ browses in the menu and confirms the changes made. ▪ MR: ▶ toggles the display between the measurement and the date/time.

2.3 DISPLAY

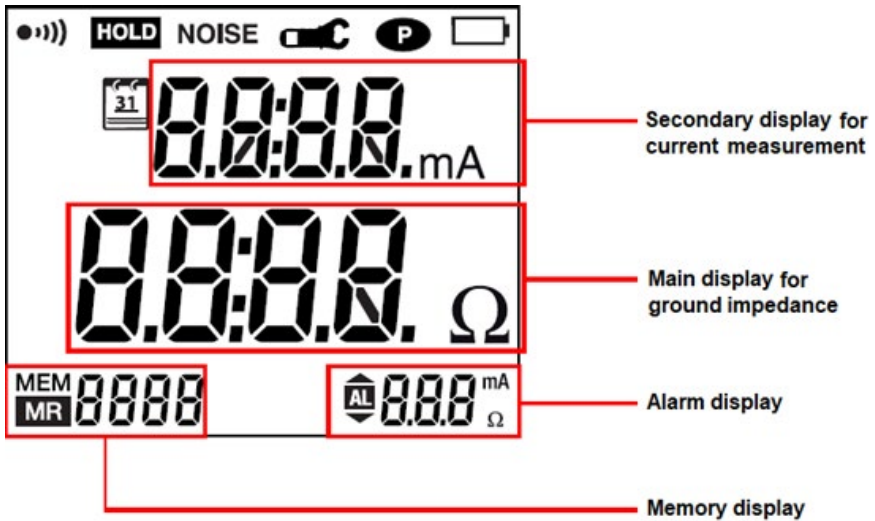

When the measurement exceeds the limits of the measurement range, the instrument displays **OR**.

2.4 INSERTING BATTERIES

Refer to § 5.2.

2.5 DATE AND TIME SETUP

The first time you turn **ON** the instrument by turning the switch to **Ω+A**, the instrument prompts you to set the date.

The year blinks, indicating it can be edited. Set it using the ▲ and ▼ keys.



Then press the ► key; the month blinks. Set it using ▲ and ▼.



Press ►. The date blinks; set it using ▲ and ▼ and confirm by pressing ►.



The instrument then displays the time format. Choose 24 h or 12 h (A or P) using ▲ and ▼.



Confirm by pressing ►. The hours reading blinks. Set it using ▲ and ▼ and confirm by pressing ►.



The minutes reading blinks. Set it using ▲ and ▼ and confirm with ►.



3. OPERATION

3.1 GENERAL

When turned **ON**, the instrument performs self-calibration. The jaws of the clamp must therefore be closed and not clamped around any conductor.

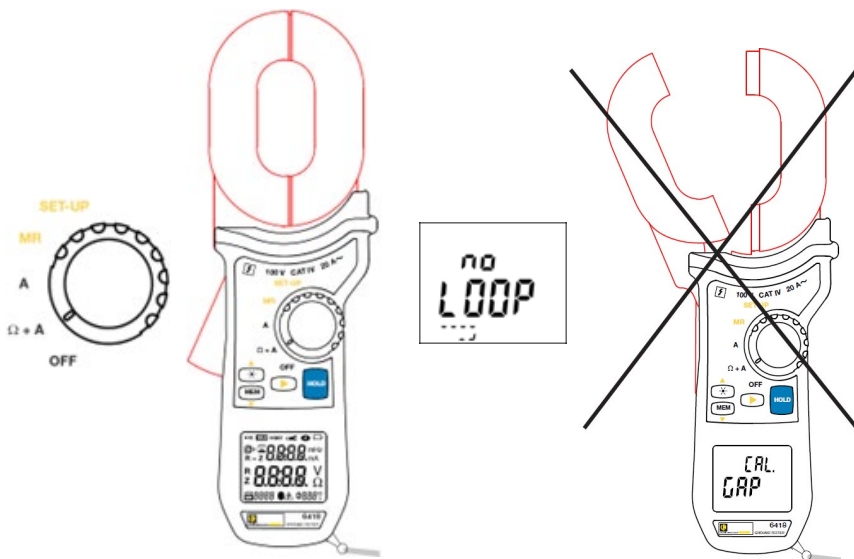

If the instrument fails to complete self-calibration, the error message **Err. CAL** is displayed. If this happens, turn the instrument **OFF** and ensure the air gaps are clean. Then turn the instrument **ON**.

3.2 IMPEDANCE AND CURRENT MEASUREMENT

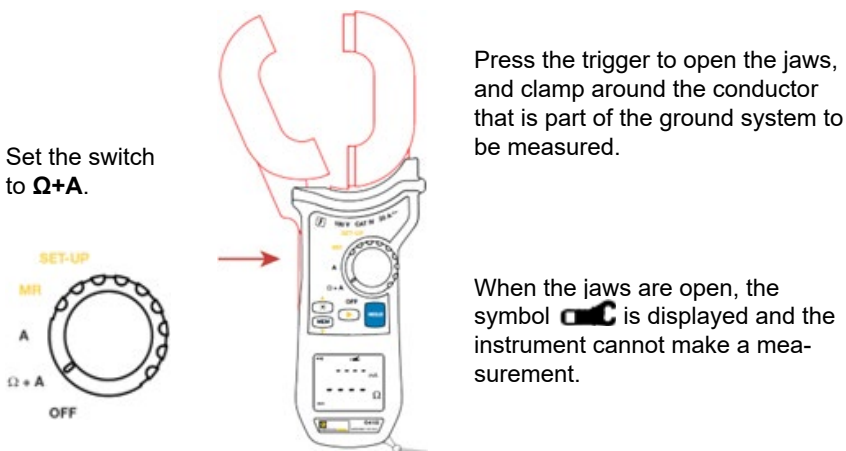

3.2.1 Connection

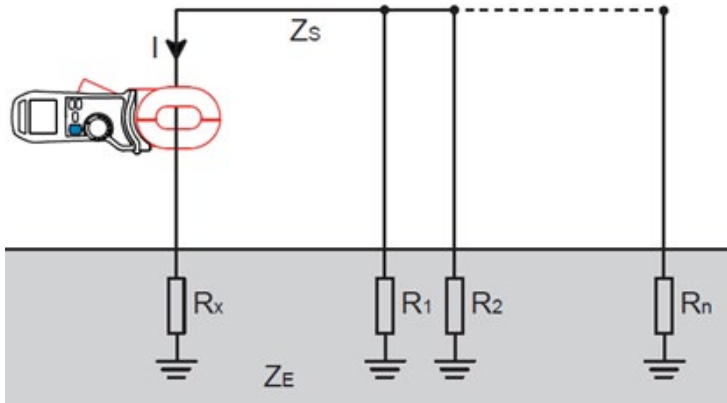

The ground electrode to be measured (R_x) is in a series/parallel arrangement with other ground electrodes via the earth impedance (Z_E) and physical connection to other resistance paths (Z_s). The measured impedance will be slightly greater than R_x assuming the downstream impedance is very low. For example: If R_x is 21 Ω and Z_s/R_1 - R_n is effectively 0.6 Ω , the Model 6418 will read 21.6 Ω .



NOTE: During the impedance measurement, the instrument emits an intermittent audible **beeping** signal. This is caused by the measurement frequency that flows in the measurement head. The sound can vary as a function of the frequency and amplitude of the current measured. This sound is normal and cannot be eliminated.

3.2.2 Freezing And/Or Storing A Measurement

When the measurement has stabilized, you can press the **HOLD** key to freeze the measurement and/or **MEM** to record the measurement.

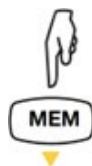
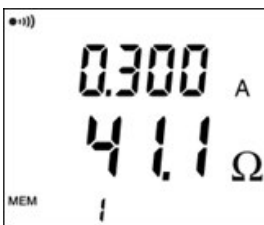

3.2.3 Auto-Hold Function

The **AUTO-HOLD** function (see § 3.4), freezes the measurement automatically when the jaws of the clamp are opened. This can be useful when you have only one hand free to make a measurement.

3.2.4 Alarms

To facilitate making measurements, you can program an alarm on the impedance measurement (see § 3.4) and/or the current measurement (see § 3.4). You can then be aware whether the measurement is acceptable without looking at the display.



The alarm indicator on the display blinks and the instrument emits a continuous audible signal.

To eliminate the audible signal, press and hold the ► key.



If you set alarms on both the impedance and the current, and both alarm thresholds are exceeded, the alarm on the current has priority.

3.3 CURRENT MEASUREMENT

The current measurement alone is identical to the current measurement with the impedance measurement.

Set the switch to **A**.

PRESS the trigger to open the jaws of the clamp and clamp the conductor in which the current to be measured flows.

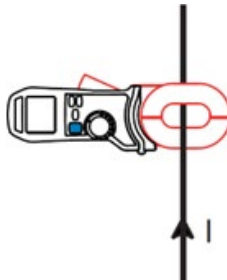
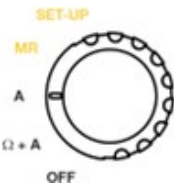

When the measurement has stabilized, you can press the **HOLD** key to freeze it and/or **MEM** to record it in memory. You can also use the **AUTO-HOLD** function (see § 3.4) to freeze the measurement automatically when the clamp jaws are opened. This can be useful when you have only one hand free to make a measurement. To facilitate making measurements, you can configure an alarm on the current measurement value (see § 3.4).

3.4 CONFIGURATION (SET-UP)

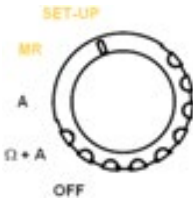

Set the switch to **SET-UP**.

Use the **▼** and **▲** keys to scroll through the screens of the **SET-UP** menu.

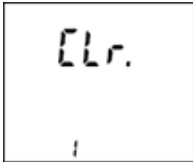

CLR (erase memory) menu.

PRESS the **▶** key to enter the **CLR** menu.

To cancel, **PRESS** **▶**.

To erase all records, **PRESS** and **HOLD** the **▲** and **▼** keys simultaneously. The instrument emits 5 audible beeps before erasing the memory.

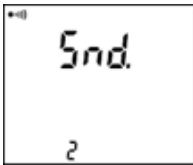

SND menu (activation of the sound).

PRESS **▶** to enter the **SND** menu. Use **▲** and **▼** to display or hide the **●)))** symbol.

When **●)))** is displayed, the instrument emits an audible signal when keys are pressed and when alarm thresholds are crossed.

Confirm by **PRESSING** **▶**.

During the measurements (when the switch is set to **Ω+A** or **A**), a long press on **▶** activates/deactivates the audible signal.

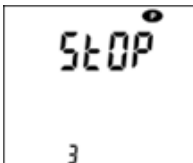

STOP menu (automatic standby).

PRESS **▶** to enter the **STOP** menu. Use **▲** and **▼** to display or hide the **P** symbol (permanent operation).

When **P** is displayed, automatic switching of the instrument to standby at the end of 5 minutes is disabled. Confirm by **PRESSING** **▶**.

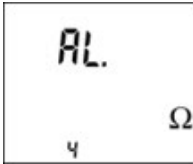

ALΩ menu (impedance alarm).

PRESS ► to enter the **ALΩ** menu. Use **▲** and **▼** to scroll through the display:

■ 10 Ω: no impedance alarm.

■ 10 Ω: impedance alarm activates when impedance > 10 Ω.

■ 10 Ω: impedance alarm activates when impedance < 10 Ω.

PRESS ►; the alarm threshold blinks. Set it using **▲** and **▼**.

Acceptable values are between (1 and 199) Ω.
A long press scrolls the values faster.

Confirm by **PRESSING ►**.

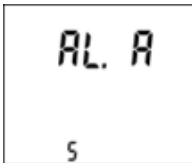

AL A menu (current alarm).

PRESS ► to enter the **AL A** menu. Use **▲** and **▼** to scroll through the display:

■ 30 mA: no current measurement alarm.

■ 30 mA: current alarm activates when current > 30 mA.

PRESS ►; the alarm threshold blink. Set it using **▲** and **▼**. Acceptable values are between (1 mA and 20.0 A). A long press scrolls the values faster.

PRESS ► to confirm.

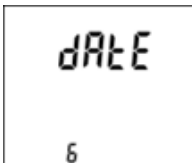

DATE menu (setting of the date).

PRESS ► to enter the **DATE** menu. Use **▲** and **▼** to set the year. **PRESS ►**; the month setting blinks. Set it using **▲** and **▼**.

Do the same for the day setting and confirm with the **►** key.

For a more detailed procedure, see § 2.5.

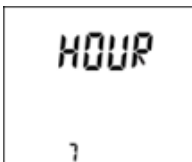

HOUR menu (setting of the time).

PRESS ► to enter the **HOUR** menu. Use **▲** and **▼** to choose 24 h or 12 h (A or P) form. **PRESS ►**; the hours setting blinks. Set this using **▲** and **▼**.

PRESS ►; the minutes setting blinks. Set this using **▲** and **▼**; confirm by **PRESSING ►**.

For a more detailed procedure, see § 2.5.



HOLD menu (activation of the AUTO-HOLD function).

PRESS ► to enter the **AUTO-HOLD** menu. Use ▲ and ▼ to display or hide the  symbol. When this symbol is displayed, the AUTO-HOLD function is activated. In this mode, when the measurement is stable, it is frozen when the clamp is opened.

Confirm by **PRESSING ►**.

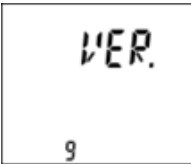

VER menu (display of the software version).

PRESS ► to display the software version number.

PRESS ▼ to display the instrument serial number.



CAL menu (not used)

3.5 ERRORS

During the measurement, the instrument reports any errors.



Display of the **NOISE** symbol during the impedance measurement indicates that the current ($> 5\text{ A}$) or voltage ($Z \times I > 25\text{ V}$) is too high, making the accuracy of the displayed measurement uncertain.



When the current exceeds 10 A, the impedance measurement is not displayed (dashes appear in the measurement field).



When the impedance measurement is $> 1200 \Omega$, the instrument displays **OR**.

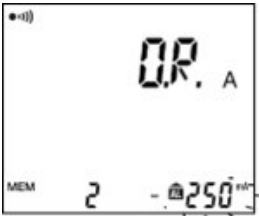

When the current measurement is $> 20 \text{ A}$, the instrument so indicates.



When the impedance measurement is $< 1 \Omega$, the display alternately indicates the measured value and **LOOP**, indicating the value is very low for a valid ground impedance measurement and most likely indicates the measurement is through a wire loop rather than through the earth.

3.6 AUTOMATIC STOP

After 5 minutes of inactivity, the instrument enters to standby mode. Press any key or turn the switch to any setting to exit standby. The instrument restarts without repeating the calibration procedure if it has not been on standby for more than 15 minutes. It is possible to disable automatic standby; refer to § 3.4 (STOP menu). The **P** symbol is then displayed.

3.7 STORAGE

3.7.1 Recording A Measurement

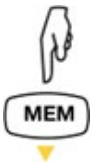

To record a measurement, **PRESS** the **MEM** key.

You can first **PRESS** the **HOLD** key to freeze the measurement.



NOTE: To record a measurement, the batteries must not be discharged (the  symbol must not be displayed).



The measurement is recorded in the memory slot of which the number is displayed (in this example, slot number 2).

It is recorded with all accompanying information:

- date and time
- any alarms and their status (triggered or not)
- any errors (**NOISE**, **OR**, **LOOP**)
- ancillary displays (**HOLD**, )

3.7.2 Viewing Recordings

Set the switch to **MR**.

The instrument displays the last measurement recorded. **PRESS ▶** to display the date and time.

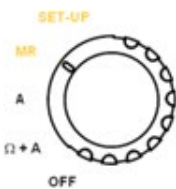

Use **▲** and **▼** to scroll through all of the recorded measurements.

3.7.3 Erasing All Recordings

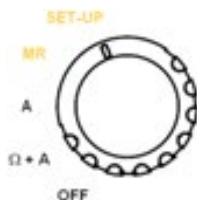

Set the switch to **SET-UP.**, then follow the procedure described in § 3.4 in the **CLR** menu.

When you return to the **MR** setting, the instrument indicates that the memory is empty.

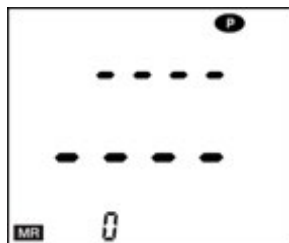

3.7.4 Memory Full

You can record up to 300 measurements (numbered from 0 to 299).

If you continue recording, measurement number 300 overwrites measurement number 0, measurement 301 overwrites measurement 1, and so on.

The instrument reports this by alternately displaying **FULL** and the memory slot number.

You can continue in this way up to number 9999, at which point recording becomes disabled and you must erase the memory to be able to resume recording.

4. TECHNICAL CHARACTERISTICS

4.1 GENERAL REFERENCE CONDITIONS

Quantities of Influence	Reference Values
Temperature	73 °F ± 5 °F (23 °C ± 3 °C)
Relative humidity	50 ± 10 % RH
Supply voltage	6 ± 0.2 V
Electric field	< 1 V/m
Magnetic field	< 40 A/m
Operating position	clamp horizontal
Position of the conductor in the jaws	centered
Adjacent conductors carrying current in impedance measurement	At least 3.9 in (10 cm)
Magnetic mass	At least 3.9 in (10 cm)
Frequency	50 Hz, sinusoidal
Level of distortion	< 0.5 %
Current present in impedance measurement	0 mA

The **intrinsic uncertainty** is the error defined under the conditions of reference.

The **operational uncertainty** is the intrinsic uncertainty plus the variation of the quantities of influence (position, supply voltage, temperature) as defined in standard IEC 61557. The uncertainties are expressed as a percentage of the reading (R) and as a number of display counts (ct): $\pm (a \% R + \# \text{ ct})$.

4.2 ELECTRICAL CHARACTERISTICS

4.2.1 Impedance Measurements

Particular conditions of reference

Inductance in series with the resistance: zero

Specified Measurement Range	0.010 to 0.099 Ω	0.10 to 0.99 Ω	1.0 to 49.9 Ω	50 to 149 Ω
Resolution (ct)	1 m Ω	10 m Ω	100 m Ω	1 Ω
Intrinsic uncertainty (δ)	$\pm (1.5 \% R + 0.01 \Omega)$	$\pm (1.5 \% R + 2 \text{ ct})$	$\pm (1.5 \% R + 2 \text{ ct})$	$\pm (2.5 \% R + 2 \text{ ct})$
No-load voltage	$\leq 45 \text{ mV to } 2083 \text{ Hz}$			

Specified Measurement Range	150 to 245 Ω	250 to 440 Ω	450 to 640 Ω	650 to 1200 Ω
Resolution (ct)	5 Ω	10 Ω	10 Ω	50 Ω
Intrinsic uncertainty (δ)	$\pm (5 \% R + 2 \text{ ct})$	$\pm (10 \% R + 2 \text{ ct})$	$\pm (15 \% R + 2 \text{ ct})$	$\pm (20 \% R + 2 \text{ ct})$
No-load voltage	$\leq 45 \text{ mV to } 2083 \text{ Hz}$			

4.2.2 Current Measurements

Particular conditions of reference

Frequency of the signal (47 to 800) Hz

Specified Measurement Range	0.500 to 9.950 mA	10.00 to 99.90 mA	100.0 to 299.0 mA	0.300 to 2.990 A
Resolution (ct)	50 μA	100 μA	1 mA	10 mA
Intrinsic uncertainty (δ)	$\pm (2 \% R + 200 \mu\text{A})$	$\pm (2 \% R + 1 \text{ ct})$	$\pm (2 \% R + 1 \text{ ct})$	$\pm (2 \% R + 1 \text{ ct})$

Specified Measurement Range	3.00 to 20.00 A
Resolution (ct)	100 mA
Intrinsic uncertainty (δ)	$\pm (2 \% R + 1 \text{ ct})$



WARNING: Beyond 20 A and 800 Hz, the clamp may overheat to a dangerous level.

4.2.3 Storage

Number of records: 300

4.3 INFLUENCES

Z = impedance

I = current

δ = intrinsic uncertainty given in § 4.2

ct = resolution given in § 4.2

4.3.1 Impedance Measurement:

Quantities of Influence	Range of Influence	Influence				
		Typical		Maximum		
Temperature	(-4 to 131) °F (-20 to +55) °C	0.5 δ / 10 °C ± ct		1.5 δ / 10 °C + ct		
Relative Humidity	(10 to 90) % RH	1 δ ± ct		2 δ ± ct		
Supply Voltage	(4 to 6.5) V	0.05 δ ± ct		0.1 δ ± ct		
Position of Conductor	from the edge to the center	Z < 450 Ω 0.2 δ ± ct	Z ≥ 450 Ω 0.5 δ ± ct	Z < 450 Ω 0.4 δ ± ct	Z ≥ 450 Ω 1 δ ± ct	
Position of Clamp	+/- 180 °	Z < 450 Ω 0.25 δ ± ct	Z ≥ 450 Ω 0.5 δ ± ct	Z < 450 Ω 0.5 δ ± ct	Z ≥ 450 Ω 1 δ ± ct	
Proximity to Magnetic Mass	Sheet steel 1 mm thick against air gap	0.1 δ ± ct		0.5 δ ± ct		
Magnetic Field 50/60 Hz	30 A/m	0.05 δ ± ct		0.1 δ ± ct		
Adjacent Conductor	I < 40 A	Z < 250 Ω 0.25 δ ± ct	Z ≥ 250 Ω 0.4 δ ± ct	Z < 250 Ω 0.5 δ ± ct	Z ≥ 250 Ω 0.8 δ ± ct	
Leakage current in the grounding system from (50 to 60) Hz i < 10 A. Zxl > 75 V	Z < 100 Ω	Zxl < 20 V	0.5 δ ± ct		1 δ ± ct	
		20 V ≤ Zxl < 40 V	1 δ ± ct		3 δ ± ct	
		40 V ≤ Zxl	2 δ ± ct		4 δ ± ct	
	Z ≥ 100 Ω	0.5 δ ± ct		1 δ ± ct		
Ground Inductance	(0 to 500) μH	Instrument displays Z at measurement frequency (2083 Hz)				

4.3.2 Current Measurement:

Quantities of Influence	Range of Influence	Influence	
		Typical	Maximum
Temperature	(-4 to 131) °F (-20 to +55) °C	0.5 δ / 10 °C ± ct	1.5 δ / 10 °C + ct
Relative Humidity	(10 to 90) % RH	0.5 δ ± ct	1 δ ± ct
Supply Voltage	(4 to 6.5) V	0.05 δ ± ct	0.1 δ ± ct
Position of Conductor	from the edge to the center	0.05 δ ± ct	0.2 δ ± ct
Position of Clamp	+/- 180 °	0.1 δ ± ct	0.25 δ ± ct
Proximity to Magnetic Mass	Steel sheet 1 mm thick against air gap	0.1 δ ± ct	0.2 δ ± ct
Magnetic Field 50/60 Hz	10 A/m	0.75 mA	1.5 mA
	30 A/m	2 mA	4.5 mA
	100 A/m	8 mA	15 mA
Deformation of the leakage current	IEC 61557-13 5 % to 150 Hz at 0° 6 % to 250 Hz at 180° 5 % to 350 Hz at 0°	0.05 δ ± ct	0.1 δ ± ct
Adjacent Conductor	I < 40 A	> 70 dB	> 66 dB
Frequency of the Leakage Current	(47 to 800) Hz ¹	0.5 δ ± ct	1 δ ± ct

1: For the whole current measurement range

4.4 POWER SUPPLY

The instrument is powered by (4) 1.5 V AA batteries (LR6 alkaline; NiMH rechargeable can also be used). The voltage range ensuring proper operation is (4 to 6.5) V. The battery life of the instrument is 12 h (approximately 1440 30-second measurements).

4.5 ENVIRONMENTAL CONDITIONS

The conditions of ambient temperature and relative humidity are illustrated in the following graph:

1 = Domain of reference

2 = Domain of use

3 = Domain of storage without batteries

% RH

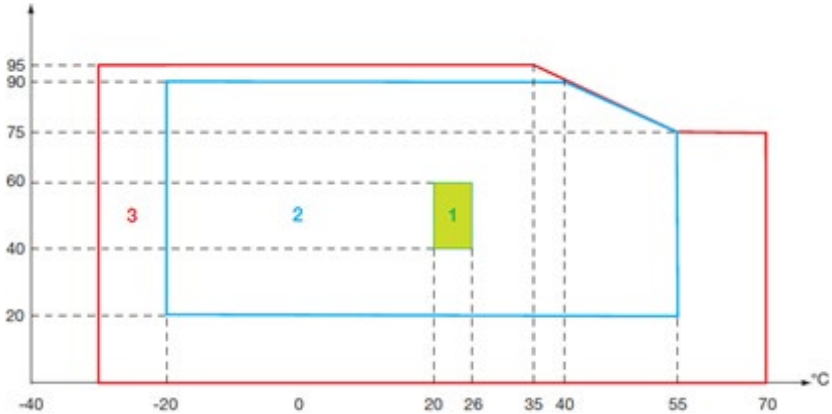

Indoor use

Altitude: < 6500 ft (< 2000 m)

Pollution degree 2

4.6 MECHANICAL CHARACTERISTICS

Dimensions (L x W x H): 11.8 x 4.2 x 2.2 in (300 x 106 x 5) mm

Weight: approximately 2.6 lb (1.2 kg)

Clamping diameter: 1.26 in (32 mm) or 1.18 x 1.57 in (30 x 40 mm) or 0.79 x 2.17 in (20 x 55 mm) bar

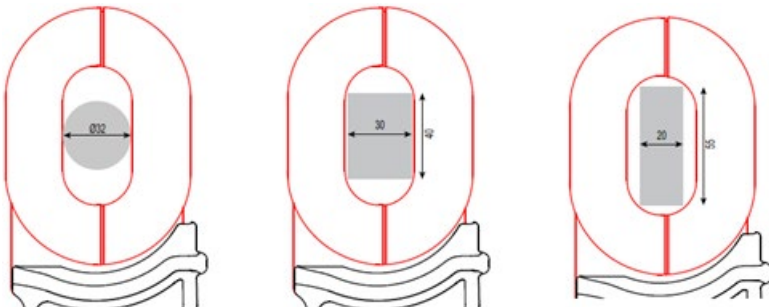

Ingress protection: IP40 per IEC 60529

4.7 COMPLIANCE WITH INTERNATIONAL STANDARDS

The instrument is compliant with standard IEC 61010-1 and IEC 61010-2-032, 100 V CAT IV or 150 V CAT III.

4.8 ELECTROMAGNETIC COMPATIBILITY (EMC)

The instrument is compliant with standard IEC 61326-1.

5. MAINTENANCE



WARNING: Except for the batteries, the device does not contain any parts that can be replaced by untrained or unaccredited personnel. Any unauthorized work or part replacement with equivalents may compromise safety, instrument performance and the warranty.

5.1 CLEANING

- Disconnect everything connected to the instrument and set the switch to **OFF**.
- Use a soft cloth, dampened with soapy water.
- Rinse with a damp cloth and dry rapidly with a dry cloth or forced air.
- Do not use alcohol, solvents, or hydrocarbons.
- Do not use the instrument again until it has completely dried. Keep the air gap of the clamp perfectly clean.

5.2 BATTERY REPLACEMENT

The  symbol on the display screen blinks when batteries are low. This symbol is displayed steadily when the batteries require replacement.

1. Disconnect everything connected to the instrument and set the switch to **OFF**.
2. Turn the instrument over and unscrew the 2 captive screws securing the battery compartment cover.

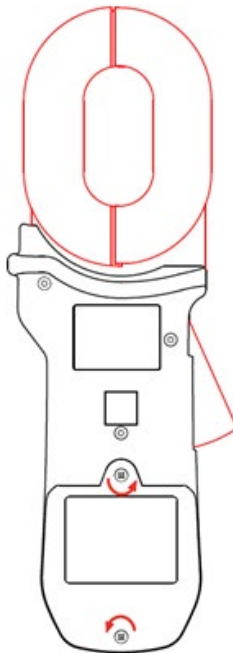

3. Remove the battery compartment cover.
4. Remove the batteries from the compartment.

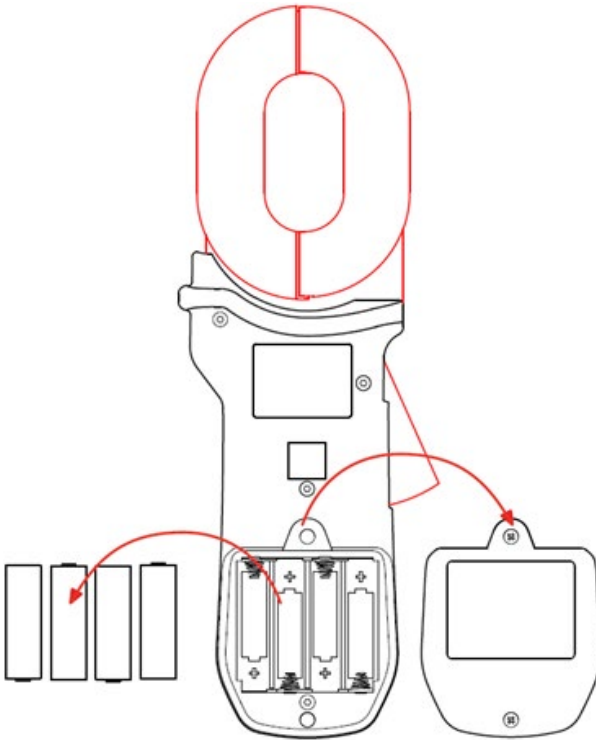

Do not treat spent batteries as ordinary household waste. Take them to the appropriate collection facility for recycling.

5. Insert new batteries in the compartment, observing polarities.
6. Replace the battery compartment cover and ensure it is completely and correctly closed.
7. Screw the two captive screws back in to place.



NOTE: Instrument date and time settings are saved for several minutes, long enough for you to change the batteries. If, however, the date and time are lost, the instrument will prompt you to reset them when it is turned ON (see § 2.5).

5.3 REPAIR AND CALIBRATION

To ensure that your instrument meets factory specifications, we recommend that the instrument be sent back to our factory Service Center at one-year intervals for recalibration or as required by other standards or internal procedures.

For instrument repair and calibration:

You must contact our Service Center for a Customer Service Authorization Number (CSA#). Send an email to repair@aemc.com requesting a CSA#, you will be provided a CSA Form and other required paperwork along with the next steps to complete the request. Then return the instrument along with the signed CSA Form. This will ensure that when your instrument arrives, it will be tracked and processed promptly. Please write the CSA# on the outside of the shipping container. If the instrument is returned for calibration, we need to know if you want a standard calibration or a calibration traceable to N.I.S.T. (includes calibration certificate plus recorded calibration data).

Ship To: Chauvin Arnoux®, Inc. d.b.a. AEMC® Instruments
15 Faraday Drive • Dover, NH 03820 USA
Phone: (800) 945-2362 (Ext. 360) / (603) 749-6434 (Ext. 360)
Fax: (603) 742-2346
E-mail: repair@aemc.com

(Or contact your authorized distributor.)

Contact us for the costs for repair, standard calibration, and calibration traceable to N.I.S.T.



NOTE: You must obtain a CSA# before returning any instrument.

5.4 TECHNICAL ASSISTANCE

If you are experiencing any technical problems or require any assistance with the proper operation or application of your instrument, please call, e-mail or fax our technical support team:

Chauvin Arnoux®, Inc. d.b.a. AEMC® Instruments
Phone: (800) 343-1391 (Ext. 351)
Fax: (603) 742-2346
E-mail: techsupport@aemc.com
www.aemc.com

5.5 LIMITED WARRANTY

The instrument is warranted to the owner for a period of two years from the date of original purchase against defects in manufacture. This limited warranty is given by AEMC® Instruments, not by the distributor from whom it was purchased. This warranty is void if the unit has been tampered with, abused, or if the defect is related to service not performed by AEMC® Instruments.

Full warranty coverage and product registration is available on our website at www.aemc.com/warranty.html.

Please print the online Warranty Coverage Information for your records.

What AEMC® Instruments will do:

If a malfunction occurs within the warranty period, you may return the instrument to us for repair, provided we have your warranty registration information on file or a proof of purchase. AEMC® Instruments will repair or replace the faulty material at our discretion.

REGISTER ONLINE AT: www.aemc.com/warranty.html

5.5.1 Warranty Repairs

What you must do to return an Instrument for Warranty Repair:

First, send an email to repair@aemc.com requesting a Customer Service Authorization Number (CSA#) from our Service Department. You will be provided a CSA Form and other required paperwork along with the next steps to complete the request. Then return the instrument along with the signed CSA Form. Please write the CSA# on the outside of the shipping container. Return the instrument, postage or shipment pre-paid to:

Chauvin Arnoux®, Inc. d.b.a. AEMC® Instruments
15 Faraday Drive, Dover, NH 03820 USA
Phone: (800) 945-2362 (Ext. 360)
(603) 749-6434 (Ext. 360)
Fax: (603) 742-2346
E-mail: repair@aemc.com

Caution: To protect yourself against in-transit loss, we recommend that you insure your returned material.



NOTE: You must obtain a CSA# before returning any instrument.

NOTES:



11/23
99-MAN 100482 v03

AEMC[®] Instruments
15 Faraday Drive • Dover, NH 03820 USA
Phone: +1 (603) 749-6434 • +1 (800) 343-1391 • Fax: +1 (603) 742-2346
www.aemc.com
