

Megohmmeter Models 6526 & 6534



MEGOHMMETERS

Copyright© Chauvin Arnoux®, Inc. d.b.a. AEMC® Instruments. All rights reserved.

No part of this documentation may be reproduced in any form or by any means (including electronic storage and retrieval or translation into any other language) without prior agreement and written consent from Chauvin Arnoux®, Inc., as governed by United States and International copyright laws.

Chauvin Arnoux®, Inc. d.b.a. AEMC® Instruments
15 Faraday Drive • Dover, NH 03820 USA
Tel: (800) 945-2362 or (603) 749-6434 • Fax: (603) 742-2346

This documentation is provided **as is**, without warranty of any kind, express, implied, or otherwise. Chauvin Arnoux®, Inc. has made every reasonable effort to ensure that this documentation is accurate; but does not warrant the accuracy or completeness of the text, graphics, or other information contained in this documentation. Chauvin Arnoux®, Inc. shall not be liable for any damages, special, indirect, incidental, or inconsequential; including (but not limited to) physical, emotional or monetary damages due to lost revenues or lost profits that may result from the use of this documentation, whether or not the user of the documentation has been advised of the possibility of such damages.

Statement of Compliance

Chauvin Arnoux®, Inc. d.b.a. AEMC® Instruments certifies that this instrument has been calibrated using standards and instruments traceable to international standards.

We guarantee that at the time of shipping your instrument has met the instrument's published specifications.

An NIST traceable certificate may be requested at the time of purchase, or obtained by returning the instrument to our repair and calibration facility, for a nominal charge.

The recommended calibration interval for this instrument is 12 months and begins on the date of receipt by the customer. For recalibration, please use our calibration services. Refer to our repair and calibration section at www.aemc.com/calibration.

Serial #: _____

Catalog #: 2155.53 / 2155.55

Model #: 6526 / 6534

Please fill in the appropriate date as indicated:

Date Received: _____

Date Calibration Due: _____



Chauvin Arnoux®, Inc.
d.b.a AEMC® Instruments
www.aemc.com

TABLE OF CONTENTS

1. INTRODUCTION	7
1.1 PRECAUTIONS FOR USE	8
1.2 RECEIVING YOUR SHIPMENT.....	10
1.2 RECEIVING YOUR SHIPMENT.....	10
1.3 ORDERING INFORMATION	10
1.3.1 Accessories.....	10
1.3.2 Replacement Parts.....	10
1.4 DESCRIPTION	11
1.4.1 Model 6526 (Front).....	12
1.4.2 Model 6534 (Front)	13
1.5 BACK OF INSTRUMENT	14
1.6 TERMINALS	15
1.7 FUNCTION BUTTONS	15
1.8 LCD DISPLAY.....	16
2. OPERATION	17
2.1 SETTING UP THE INSTRUMENT.....	17
2.1.1 Configuration Settings.....	17
2.1.2 Bluetooth.....	18
2.1.3 Alarms.....	18
2.1.3.1 Activating/Deactivating the Alarm Function	18
2.1.3.2 Setting an Alarm Threshold.....	19
2.1.3.3 Viewing Alarms.....	19
2.1.4 Δ REL Function	20
2.1.5 HOLD Function	21
2.1.6 Backlighting.....	21
2.1.7 Standby Mode	21
2.2 TAKING MEASUREMENTS.....	22
2.2.1 Voltage Measurement.....	22
2.2.2 Insulation Measurement	23
2.2.2.1 TEST Button Operation.....	25
2.2.2.2 Timed Tests.....	25
2.2.2.3 Remote Control Probe (Optional)	27
2.2.3 Continuity Measurement	27
2.2.3.1 Lead Compensation	28
2.2.3.2 Continuity Measuring.....	28
2.2.4 Resistance Measurement.....	30
2.2.5 Capacitance Measurement (Model 6526).....	30

2.3 RECORDING DATA	31
2.3.1 Recording a Measurement	31
2.3.2 Viewing Stored Recordings	32
2.3.3 Deleting Recordings	33
2.3.3.1 Deleting a Single Recording.....	33
2.3.3.2 Deleting All Records	33
3. SPECIFICATIONS	34
3.1 GENERAL REFERENCE CONDITIONS.....	34
3.2 ELECTRICAL SPECIFICATIONS	34
3.2.1 Voltage Measurement.....	34
3.2.2 Frequency Measurement.....	34
3.2.3 Insulation Measurement	35
3.2.4 Continuity Measurement	37
3.2.5 Resistance Measurement.....	37
3.2.6 Capacitance Measurement (Model 6526).....	37
3.2.7 Timer.....	38
3.2.8 Storage Memory.....	38
3.2.9 Bluetooth	38
3.3 OPERATING ENVIRONMENT	38
3.3.1 Voltage Measurement.....	38
3.3.2 Insulation Measurement	38
3.3.3 Resistance and Continuity Measurement	40
3.3.4 Capacitance Measurement (Models 6526)	40
3.4 INTRINSIC UNCERTAINTY AND OPERATING UNCERTAINTY.....	41
3.5 POWER SUPPLY	41
3.6 ENVIRONMENTAL CONDITIONS	41
3.7 MECHANICAL SPECIFICATIONS	42
3.8 SAFETY STANDARDS.....	42
4. DATAVIEW® SOFTWARE.....	43
4.1 INSTALLING DATAVIEW®	43
4.2 MEGOHMMETER CONTROL PANEL	44
4.3 CONNECTING TO THE COMPUTER.....	44
4.3.1 Enabling Bluetooth on the Instrument.....	44
4.3.2 Pairing the Instrument to the Computer	45
4.3.3 Connecting the Instrument with the Control Panel.....	45















5. MAINTENANCE AND TROUBLESHOOTING.....	46
5.1 MAINTENANCE	46
5.1.1 Cleaning	46
5.1.2 Replacing the Batteries.....	46
5.2 TROUBLESHOOTING.....	48
5.2.1 Errors	48
5.2.1.1 Voltage Present Before an Insulation Measurement.....	48
5.2.1.2 Range Exceeded During an Insulation Measurement.....	48
5.2.1.3 Voltage Present During a Continuity, Resistance, or Capacitance Measurement (Model 6526).....	48
5.2.1.4 Memory Full.....	49
5.2.2 Resetting the Instrument	49
5.3 REPAIR AND CALIBRATION	49
5.4 TECHNICAL ASSISTANCE	50
5.5 LIMITED WARRANTY	50
5.5.1 Warranty Repairs.....	51

1. INTRODUCTION

Thank you for purchasing an AEMC® Instruments **Megohmmeter Model 6526 or 6534**.

For the best results from your instrument and for your safety, you must read the enclosed operating instructions carefully and comply with the precautions for use. Only qualified and trained operators should use this product.

Symbols and Definitions

	Signifies that the instrument is protected by double or reinforced insulation
	CAUTION - Risk of Danger! Indicates a WARNING . Whenever this symbol is present, the operator must refer to the user manual before operation
	Indicates a risk of electric shock. The voltage at the parts marked with this symbol may be dangerous
	Indicates Important information to acknowledge
	The product has been declared recyclable
	Ground/Earth
	Battery
	The voltage on the terminals must not exceed 700 V
	Remote test probe
 	Chauvin Arnoux® and AEMC® Instruments have adopted an Eco-Design approach in order to design this instrument. Analysis of the complete lifecycle has enabled us to control and optimize the effects of the product on the environment. In particular this instrument exceeds regulation requirements with respect to recycling and reuse
	This product complies with the Low Voltage & Electromagnetic Compatibility European directives (73/23/CEE & 89/336/CEE)
 	In the European Union, this product is subject to a separate collection system for recycling electrical and electronic components in accordance with directive WEEE 2002/96/EC

Definition of Measurement Categories (CAT)

CAT IV: Corresponds to measurements performed at the primary electrical supply (< 1000 V).

Example: primary overcurrent protection devices, ripple control units, and meters.

CAT III: Corresponds to measurements performed in the building installation at the distribution level.

Example: hardwired equipment in fixed installation and circuit breakers.

CAT II: Corresponds to measurements performed on circuits directly connected to the electrical distribution system.

Example: measurements on household appliances and portable tools.

1.1 PRECAUTIONS FOR USE

This instrument is compliant with safety standard IEC 61010-2-030, and the leads are compliant with IEC 61010-031, for voltages up to 600 V in CAT IV or 1000 V in CAT III.

Failure to observe the safety instructions may result in electric shock, fire, explosion, destruction of the device, or destruction of the installations.

- Carefully read and understand all precautions for use.
- Be aware of all electrical hazards when using this instrument.
- Using this instrument other than as specified may compromise its user protection features.
- The safety of any system in which this instrument is incorporated is the responsibility of the integrator of the system.
- This instrument can be used on CAT IV installations, for voltages not exceeding 600 VRMS with respect to ground or 700 VRMS maximum between terminals.
- Do not use the instrument on networks whose voltage or category exceeds those specified in this manual.
- Observe all environmental conditions of use (see § 3).
- Except for voltage measurements, take no measurements on electrically **live** systems.
- Do not use the instrument if it appears damaged, incomplete, or poorly closed.
- Before each use, check the condition of the insulation on the leads, housing, and accessories. Any part on which the insulation is deteriorated (even partially) must be set aside for repair or scrapping.
- Using the instrument without its battery compartment cover may result in electric shock to the user.
- Before using your instrument, ensure it is completely dry.
- Use only the leads and accessories supplied. The use of leads (or other accessories) of a lower voltage rating or category limits the use of the instrument/leads (or accessories) combination to the lowest category and service voltage.

- When handling the leads, test probes, and alligator clips, keep your fingers behind the physical guards.
- Before removing the battery compartment cover, ensure all measurement leads and accessories are disconnected. Replace all batteries at once. Use alkaline batteries.
- Use personal protection equipment where appropriate.
- All troubleshooting and metrological checks must be done by competent, accredited personnel.

PRODUCT PACKAGING (2155.53 / 2155.55)



One of the following:
 Megohmmeter Model 6526 - Cat. #2155.53
 Megohmmeter Model 6534 - Cat. #2155.55



Soft Carrying Pouch
 (7.75 x 9.25 x 2.75) in
 Cat. #2119.02



(1) 4 GB USB Drive
 with User Manual &
 Dataview® Software



Two color-coded (red/black) 1.5 m test leads,
 two alligator clips, two grip probes and
 one test probe (black)

Also Included:

(1) (6) AA Batteries

1.2 RECEIVING YOUR SHIPMENT

Upon receiving your shipment, make sure that the contents are consistent with the packing list. Notify your distributor of any missing items. If the equipment appears to be damaged, file a claim immediately with the carrier, and notify your distributor at once with a detailed description of any damage. Save the damaged packing container to substantiate your claim.

1.3 ORDERING INFORMATION

Megohmmeter Model 6526..... **Cat. #2155.53**

Includes soft carrying pouch, (2) color-coded test leads and alligator clips (red/black), (1) test probe (black), (6) AA batteries, quick start guide, and USB drive with DataView® software and user manual.

Megohmmeter Model 6534..... **Cat. #2155.55**

Includes soft carrying pouch, (2) color-coded grip probes (red/black), (2) color-coded test leads and alligator clips (red/black), (1) test probe (black), (6) AA batteries, quick start guide, and USB drive with DataView® software and user manual.

1.3.1 Accessories

Remote Test Probe **Cat. #2155.75**

Case - Field Case (Waterproof)..... **Cat. #2155.77**

Continuity Probe..... **Cat. #2138.54**

Probe – Red test probe (1000 V Cat IV, 15 A, UL V2) **Cat. #5000.98**

1.3.2 Replacement Parts

Carrying Pouch for Megohmmeters, Multimeters, etc. **Cat. #2119.02**

Probe - Set of 2, Color-coded (Red/Black) Grip Probes..... **Cat. #2152.26**

Probe - Black test probe (1000 V Cat IV, 15 A, UL)..... **Cat. #5000.30**

Lead - Set of 2, 5 ft silicone color-coded (red/black) with 4 mm

straight/right banana plugs (Rated 1000 V, CAT IV, UL) **Cat. #5000.94**

Clip - Safety Alligator - Black (1000 V CAT IV, 15 A, UL V2) **Cat. #5000.99**

Clip - Safety Alligator - Red (1000 V CAT IV, 15 A, UL V2) **Cat. #5100.00**

Order Accessories and Replacement Parts Directly Online

Check our Storefront at www.aemc.com/store for availability

Dataview® Software Updates are Available at www.aemc.com

1.4 DESCRIPTION

The Megohmmeters Models 6526 and 6534 are portable measuring instruments with digital displays. They are powered by batteries. These instruments can check the safety of electrical installations. For example, they can be used to test new installations before they are powered up, check an existing installation in a power-off condition, or troubleshoot an installation.

The Model 6534 is designed for applications in the electronics industry, including testing the immunity of walls and floors to electrostatic discharges (ESD).

Features Include:

	Model 6526	Model 6534
Insulation Test Voltages	50 V, 100 V, 250 V, 500 V, and 1000 V	10 V, 25 V, 100 V, 250 V, and 500 V
Insulation Resistance	10 k Ω to 200 G Ω	2 k Ω to 50 G Ω
PI and DAR Ratios Calculation	✓	–
Continuity Measurement	✓	✓
Resistance Measurement	✓	✓
Programmable Alarms	✓	✓
Frequency Measurement	✓	–
Capacitance Measurement	✓	–
Distance Measurement	–	–
Data Storage	✓	✓
Bluetooth Communication	✓	✓

1.4.1 Model 6526 (Front)

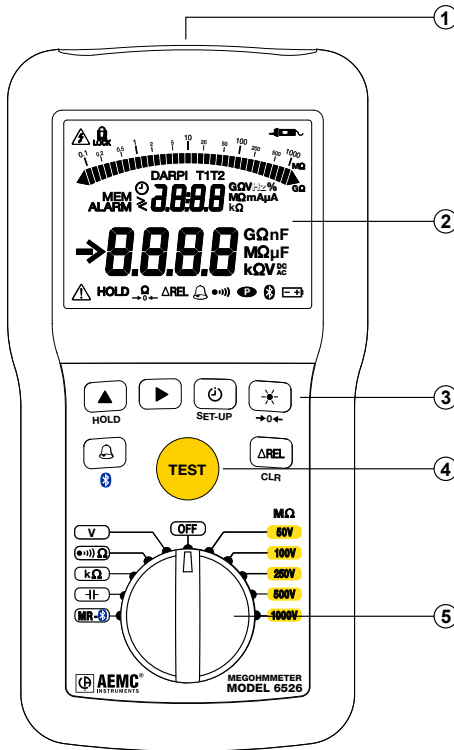

Figure 1

1. Input terminals
2. Blue backlit LCD
3. Six function buttons (see § 1.7)
4. **TEST** button to start insulation measurements (see § 2.2.2.1)
5. Eleven-position rotary switch to choose the function or to turn the instrument OFF

1.4.2 Model 6534 (Front)

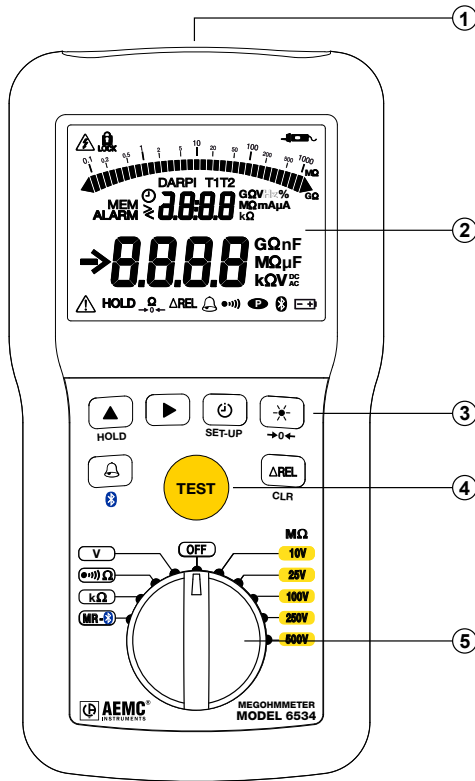

Figure 2

1. Input terminals
2. Blue backlit LCD
3. Six function buttons (see § 1.7)
4. **TEST** button to start insulation measurements (see § 2.2.2.1)
5. Ten-position rotary switch to choose the function or to turn the instrument OFF

1.5 BACK OF INSTRUMENT

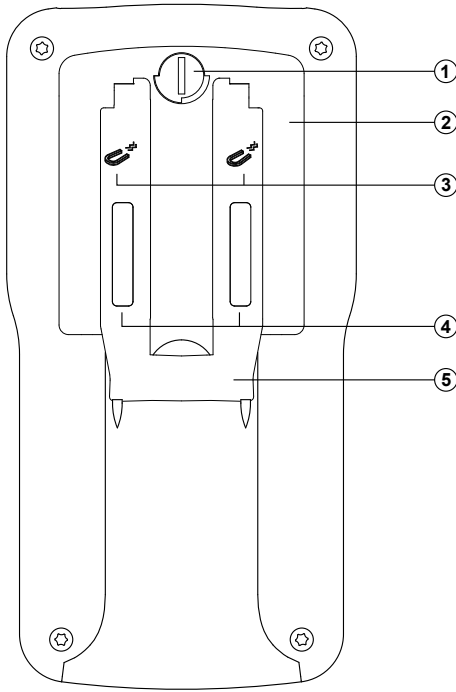

Figure 3

1. Captive quarter-turn screw
2. Battery compartment cover
3. Mounting magnets, moulded into instrument case
4. Non-skid pads
5. Stand

1.6 TERMINALS

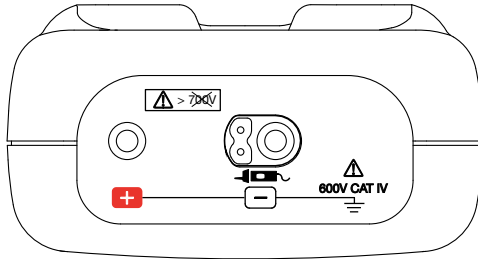

Figure 4

The instrument has one positive + terminal and one negative - terminal. The negative terminal also supports the remote probe accessory (see § 2.2.2.3).

1.7 FUNCTION BUTTONS

In general, each button has two functions. One is marked on the button, and is enabled via a short press. The second function is marked under the button, and is enabled by a long (>2 seconds) press.

BUTTON	DESCRIPTION
	Selects the Lock, PI, and DAR functions (§ 2.2.2.2).
	Toggles backlighting ON and OFF (§ 2.1.6).
HOLD	Freezes/unfreezes the displayed measurement on the LCD (§ 2.1.5).
SET-UP	Accesses the instrument's setup parameters and information (§ 2.1.1).
	Applies lead compensation in continuity testing (§ 2.2.3.1).
	Activates/deactivates alarms (§ 2.1.3).
	The and buttons allow you to: <ul style="list-style-type: none"> ▪ Modify the display and program the durations of insulation measurements (§ 2.2.2.2). ▪ Choose the continuity test current (§ 2.2.3). ▪ Program the alarm thresholds (§ 2.1.3).
ΔRel	Displays the difference between the present measurement and a stored reference measurement (§ 2.1.4).
MEM	Records measurements (§ 2.3).
CLR	Erase recorded measurements (§ 2.3.3).
	Enable Bluetooth wireless communication (§ 2.1.2).

1.8 LCD DISPLAY

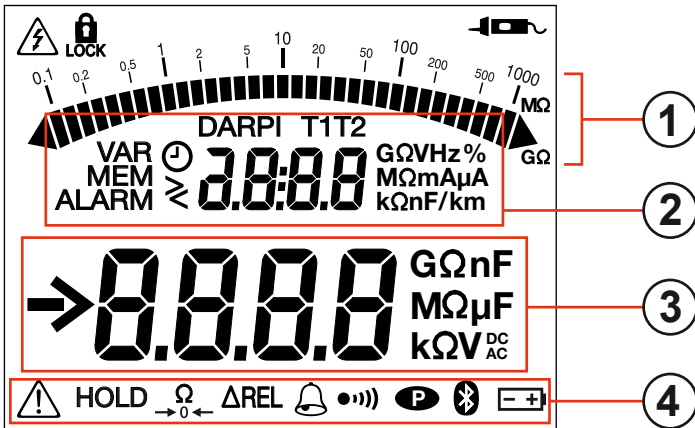

Figure 5

1. Logarithmic bar graph displays insulation measurements
2. Secondary display area
3. Main display area
4. Icons/indicators

When the measured value is below the minimum, the instrument displays **-----**.

When measuring voltage, if the reading falls outside the range defined by the positive and negative limits, the instrument displays **OL** or **- OL**.

2. OPERATION



NOTE: Except when measuring voltage, all measurements must be made on powered-off systems. Therefore check to ensure there is no voltage on the system under test before making a non-voltage measurement. When the rotary switch is set to the voltage or an insulation testing position, the instrument measures and displays any voltage present at the input terminals prior to the user pressing the test button.

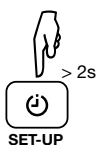

2.1 SETTING UP THE INSTRUMENT

2.1.1 Configuration Settings



A >2 second press of the SET-UP button enables you to change configuration settings on the instrument. You can then use the ▲ and ► buttons to scroll through and modify parameters.

In Set-Up mode, the ▲ button performs the following functions:

<p>1st press on ▲</p>		<p>The alarm buzzer is active. To deactivate it:</p> <ol style="list-style-type: none"> 1. Press ►. On will blink to indicate it is selected. 2. Press ▲ to change the setting to OFF. 3. Press ► to validate the change. <p>The ●))) symbol disappears from the display when you exit Set-Up.</p> <p>Note that this setting reverts to On when you turn OFF the instrument.</p>
<p>2nd press on ▲</p>		<p>Automatic switching to standby mode is activated. To deactivate it:</p> <ol style="list-style-type: none"> 1. Press ► to select OFF (the setting blinks). 2. Press ▲ to change the setting to On. 3. Press ► to validate the change. <p>The ●P symbol appears on the display when you exit Set-Up.</p> <p>Note that this setting reverts to OFF when you turn OFF the instrument.</p>
<p>3rd press on ▲</p>		<p>Displays the instrument model number.</p>

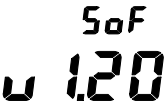
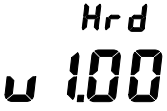
4 th press on ▲		Displays the instrument firmware version.
5 th press on ▲		Displays the instrument hardware version.
6 th press on ▲		Return to the first press.

2.1.2 Bluetooth

The instrument includes built-in Bluetooth class II capability. This enables you to connect the instrument to a computer and then communicate with it via the DataView Megohmmeter Control Panel software (see § 4.3).

Connecting the instrument to a computer is a three-step process:



1. Enable Bluetooth on the instrument (§ 4.3.1).
2. Pair the instrument to the computer using Bluetooth (§ 4.3.2).
3. Connect the instrument to the computer through the DataView Megohmmeter Control Panel (§ 4.3.3).

2.1.3 Alarms

The instrument includes an alarm function that sounds an audible buzzer when a defined alarm condition is measured.

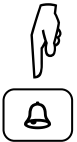
2.1.3.1 Activating/Deactivating the Alarm Function



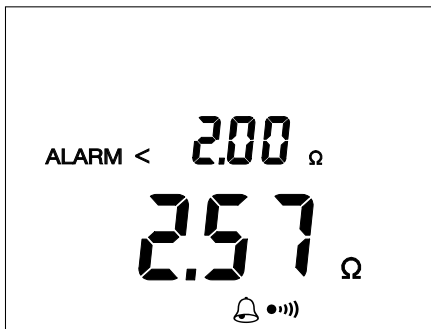

The alarm is available in insulation, resistance, and continuity measurement modes. Pressing the  button activates the alarm. The  symbol is displayed, along with the threshold value.









To turn OFF the alarm buzzer while it is sounding, press the **HOLD** button.
To deactivate an active alarm function, press the  button.

2.1.3.2 Setting an Alarm Threshold

While  is displayed indicating the alarm function is active, you can change the alarm threshold by pressing the  button (except during insulation measurements). For each testing mode, there are three pre-defined threshold values:

- Continuity: $<2 \Omega$, $<1 \Omega$ and $<0.5 \Omega$
- Resistance: $>50 \text{ k}\Omega$, $>100 \text{ k}\Omega$ and $>200 \text{ k}\Omega$
- Insulation:
 - 10 V: $<10 \text{ k}\Omega$, $<20 \text{ k}\Omega$ and $<40 \text{ k}\Omega$
 - 25 V: $<25 \text{ k}\Omega$, $<50 \text{ k}\Omega$ and $<100 \text{ k}\Omega$
 - 50 V: $<50 \text{ k}\Omega$, $<100 \text{ k}\Omega$ and $<200 \text{ k}\Omega$
 - 100 V: $<100 \text{ k}\Omega$, $<200 \text{ k}\Omega$ and $<400 \text{ k}\Omega$
 - 250 V: $<250 \text{ k}\Omega$, $<500 \text{ k}\Omega$ and $<1 \text{ M}\Omega$
 - 500 V: $<500 \text{ k}\Omega$, $<1 \text{ M}\Omega$ and $<2 \text{ M}\Omega$
 - 1000 V: $<1 \text{ M}\Omega$, $<2 \text{ M}\Omega$ and $<4 \text{ M}\Omega$

In each measurement mode, the third threshold can be replaced by a user-defined value. To do this:

1. Press the  button while the threshold value is displayed.
2. The $>$ symbol starts blinking; you can change it to $<$ by pressing the  button. This symbol indicates the direction of the alarm threshold: $<$ for a low threshold and $>$ for a high threshold.
3. To change the threshold setting, press the  button to navigate to the first digit, and then use the  button to change its value.
4. Use the  and  buttons to select and change the other digits in the threshold value, as well as the units of measurement.
5. When finished setting the threshold, press the  button to validate the setting.

2.1.3.3 Viewing Alarms

When the measurement is below a low alarm threshold or above a high alarm threshold, the instrument emits a continuous audible signal and the LCD indicates the threshold crossed:

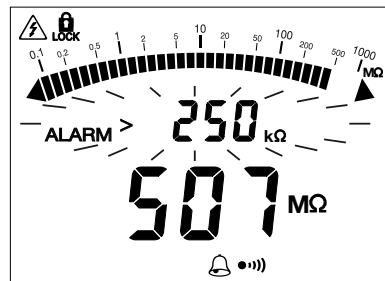
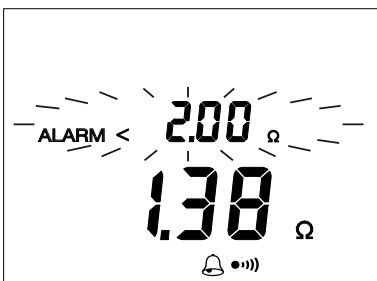

When checking continuity, this enables you to determine whether or not the continuity measurement is less than 2Ω simply by listening, without looking at the display. You can similarly check insulation quality.

2.1.4 ΔREL Function



For an insulation, resistance, or capacitance measurement, you can configure the instrument to subtract a reference value from the measured value and display the difference.

To activate this function, take a measurement, and then press the ΔREL button. This measurement becomes the reference (Rref) and will be stored and subtracted from subsequent measurement values (Rmeas). The ΔREL symbol appears on the LCD while this function is activated.

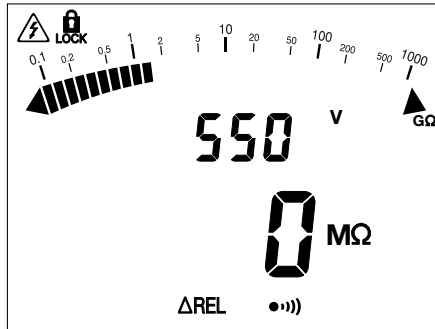

If the measured value is less than the stored value, the display becomes negative.

You can display the difference as a percentage of the reference

($\frac{R_{meas} - R_{ref}}{R_{ref}} \times 100$) by pressing the ► button until the % sign appears:

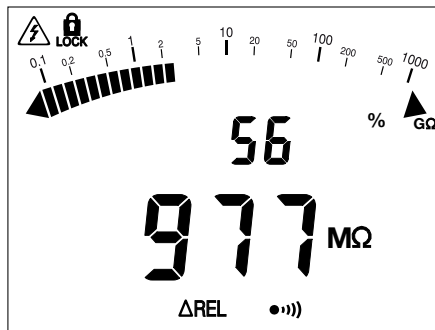

NOTE: For insulation measurements, only the digital display is modified by ΔREL. The bar graph continues to display the true measured value.

To deactivate the ΔREL function, press the ΔREL button or turn the rotary switch to another setting.

2.1.5 HOLD Function



Pressing the **HOLD** button freezes the display of the measurement. This can be done in all functions except the $M\Omega$ settings, or during a timed measurement (⏏ , **DAR**, **PI**).

To unfreeze the display, press the **HOLD** button again.

2.1.6 Backlighting



Pressing the ☀ button turns ON backlighting for the LCD.

To switch it OFF, press the ☀ button again. Otherwise, backlighting goes OFF automatically at the end of one minute.

2.1.7 Standby Mode

After 5 minutes of operation with no user activity, the instrument automatically switches to standby mode. To restore normal operation, simply press any button. The instrument returns to the state it was in prior to entering standby mode, with no loss information (value of the last measurement, compensation of the leads, ΔREL , timed mode, alarm, etc.).

Automatic switching to standby mode is disabled during:

- Insulation measurements in Lock mode and in timed mode (⏏ , **PI**, or **DAR**).
- Continuity measurements, for as long as measurements are made.

Automatic switching to standby is disabled via the SET-UP button (see § 2.1.1).

2.2 TAKING MEASUREMENTS

2.2.1 Voltage Measurement



NOTE: To ensure proper and accurate operation of the instrument, we recommend measuring a known voltage (such as an electrical outlet) before measuring unknown voltages.

1. Set the switch to **V** or to one of the **MΩ** positions.

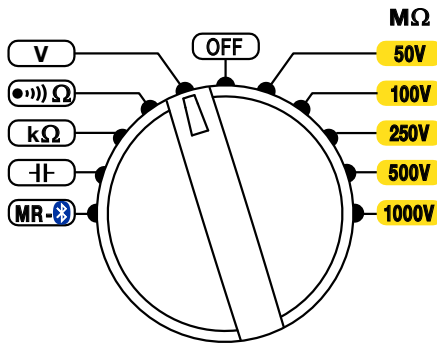

2. Using the leads, connect the system to be tested to the instrument's terminals.

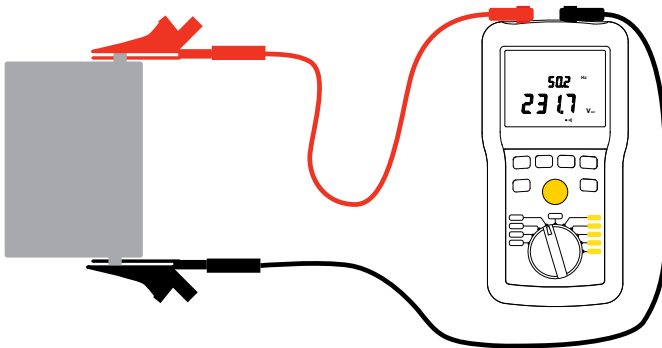

The instrument displays the voltage on the terminals. It detects whether the voltage is AC or DC; and (for Model 6526) if it is AC, displays its frequency.

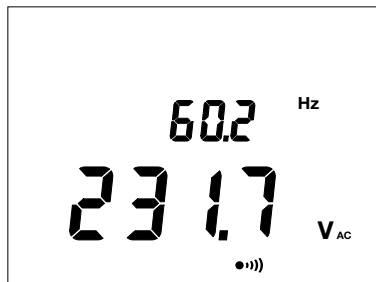

In the **MΩ** settings, the  symbol indicates that the voltage is too high (>25 V) and that insulation measurements are prohibited.

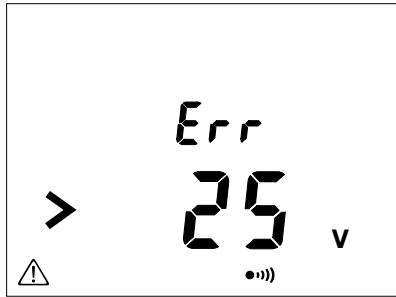

If the voltage is >15 V, continuity, resistance, and capacitance measurements are prohibited.

2.2.2 Insulation Measurement



NOTE: Insulation measurement results can be affected by the impedances of additional circuits connected in parallel or by transient currents.

Do not start any measurement while the symbol  is displayed.

1. Set the rotary switch to one of the **MΩ** positions. The test voltage depends on the voltage of the installation to be tested.

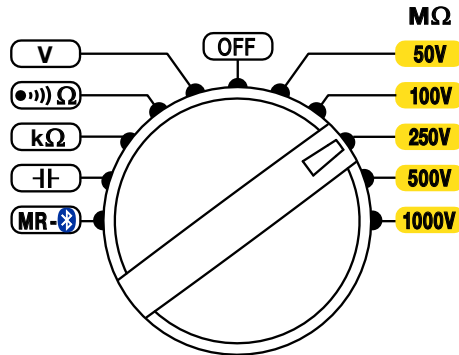

- Use the leads to connect the system to be tested to the instrument's terminals. The system under test must be powered down and discharged. When testing insulation, the typical connection is negative (black) lead to conductor and positive (red) lead to ground or the outer insulation of the device under test.

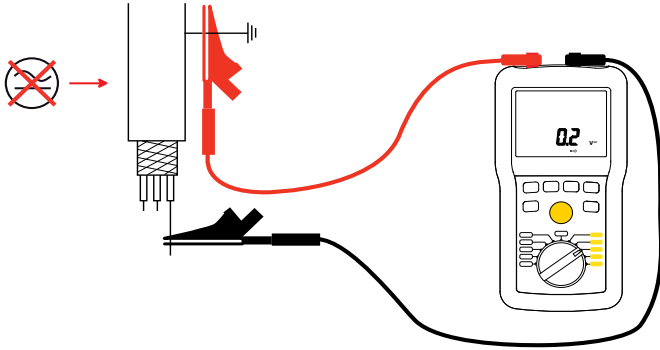

- (Optional) Press the ► button to display the current or the elapsed time. (You can also do this during the measurement.)
- Press the **TEST** button and hold it down until the displayed measurement is stable. Note that if the instrument detects a voltage greater than 25 V in the system under test, pressing the **TEST** button has no effect because the test will be prohibited.
- The resistance measurement is displayed on the LCD's main display area and on the bar graph. The secondary display area indicates the test voltage generated by the instrument.

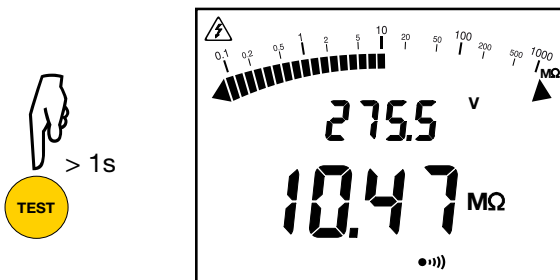

The ⚡ symbol indicates that the instrument is generating a hazardous voltage (>70 V).

- At the end of the measurement, release the **TEST** button. The instrument stops generating the test voltage and discharges the device being tested. The ⚡ symbol is displayed until the voltage on the system under test has fallen below 70 V.

NOTE: Do not disconnect the leads and do not start any measurement while the symbol ⚡ is displayed.

When you release the **TEST** button, the measurement results remain displayed until the next measurement, or the **HOLD** button is pressed, or the instrument is turned OFF.

2.2.2.1 TEST Button Operation



Pressing the **TEST** button starts an insulation measurement. In normal mode, the test voltage is generated for as long as the button is pressed. When the button is released, the measurement stops.

In **LOCK** mode, press the test button once to start the measurement, then press it a second time to stop; there is no need to keep the button pressed. However, if you do not stop the measurement, it will stop automatically after 15 minutes.

In timed test mode (, **DAR**, **PI**) press the **TEST** button once to start the measurement. The test will stop automatically at the end of the defined test duration time.

2.2.2.2 Timed Tests

The **TIMER**  button activates timed test mode. This button is active only for insulation measurements.

1st press	 LOCK	This locks the TEST button. After you start the measurement, it continues to run without requiring you to keep the TEST button pressed. The test will run until you stop it, or when 15 minutes have passed.
2nd press	 2:00	This activates timed test mode. You can set a test duration between 1 and 39:59 minutes. Use the ▶ and ▲ buttons to modify the value displayed. When the time duration is displayed, press the ▶ button to enter edit mode. When the first digit blinks, you can change it using the ▲ button. Press ▶ to go to the next digit and ▲ to change it. Then press ▶ to validate.
3rd press	PI T2 10:00	This enables the PI function. This is used to calculate the polarization index (the ratio of the measurement at 10 minutes to the measurement at 1 minute).
4th press	DAR T2 1:00	This enables the DAR function. This is used to calculate the dielectric absorption ratio (the ratio of the measurement at 1 minute to the measurement at 30 seconds).
5th press		Exits timed test mode.

When , **DAR**, or **PI** is activated, pressing the **TEST** button starts the test. The LCD displays the measurement, along with a **countdown** timer showing the time remaining in the test. The test automatically stops when the duration end time is reached and the result is displayed.



Successive presses on the ▲ button display intermediate values. These include

For :

- Programmed time, voltage, and current at the end of the measurement

For **PI** and **DAR**:

- T1 time and the voltage, current, and insulation resistance at that time
- T2 time and the voltage, current, and insulation resistance at that time

Use the following table as a guide for interpreting the results of a **DAR** or **PI** test:

DAR	PI	Condition of insulation
DAR < 1.25	PI < 2	Poor or even dangerous
1.25 ≤ DAR < 1.6	2 ≤ PI < 4	Good
1.6 ≤ DAR	4 ≤ PI	Excellent



Press the **TEST** button to return to voltage measurement.

2.2.2.3 Remote Control Probe (Optional)

The optional remote control probe is used to trigger the measurement using the **TEST** button on the probe. To use this accessory, refer to its separate operating instructions.

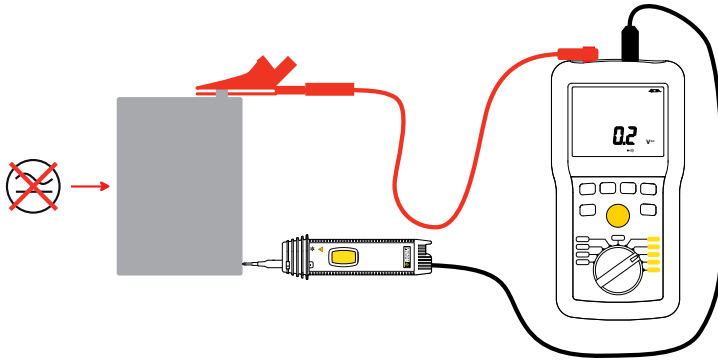

When the probe is connected, the  symbol is displayed on the instrument's LCD.

2.2.3 Continuity Measurement

Continuity measurement measures a low resistance (<10 or 100Ω depending on the current) at a high current (200 or 20) mA.

NOTE: A current of 20 mA reduces the power consumption of the instrument, increasing its battery life. However, the standard IEC 61557 requires 200 mA current for continuity testing.



If an external voltage >15 V is detected in the system under test during the continuity measurement, the instrument is protected without a fuse. The continuity measurement is stopped and the instrument reports an error until the voltage disappears.

2.2.3.1 Lead Compensation

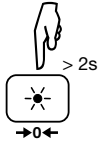

Before checking continuity, you should compensate for the resistance of the measurement leads. This ensures that the resistance measurement excludes the resistance in the leads. To do this, set the rotary switch to $\bullet\text{)))})\Omega$. Then short-circuit the measurement leads and press the $\rightarrow 0 \leftarrow$ button for >2 seconds.

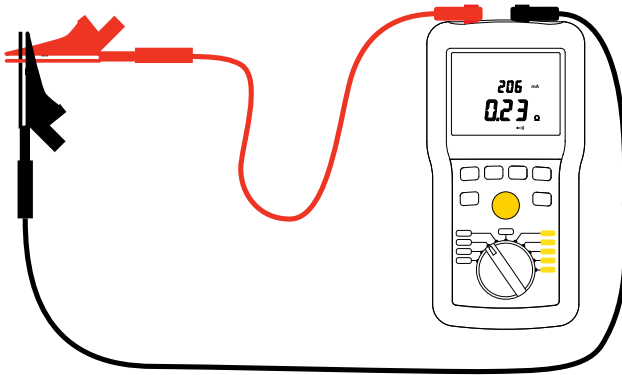

The display changes to zero and the $\rightarrow 0 \leftarrow$ symbol is displayed. The resistance of the leads will be systematically subtracted from all continuity measurements. If the resistance of the leads is >10 Ω , there is no compensation. The compensation remains in memory until the instrument is turned OFF.

If the leads are changed with no change of compensation, the display may become negative. The instrument reports that the compensation must be redone by displaying a blinking $\rightarrow 0 \leftarrow$ symbol.

To remove the compensation of the leads, leave the leads open and press the $\rightarrow 0 \leftarrow$ button for >2 seconds. The LCD displays the resistance of the leads and the $\rightarrow 0 \leftarrow$ symbol goes off.

2.2.3.2 Continuity Measuring

1. Set the rotary switch to $\bullet\text{)))})\Omega$.

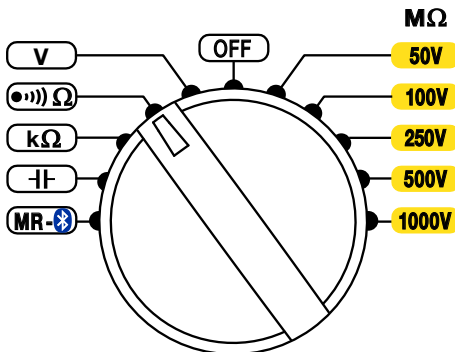

2. Press the ► button to display the measurement current. The measurement current appears blinking on the LCD. You can change the current by pressing the ► button.
3. Use the leads to connect the instrument to the system to be tested. The system to be tested must be powered down.

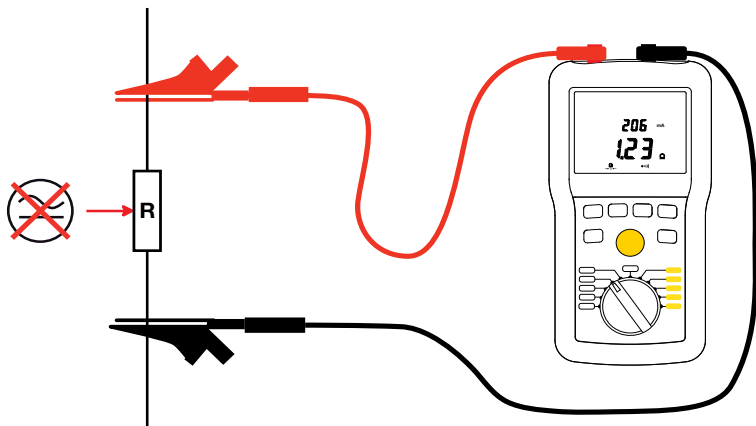

The instrument displays the resistance and the current used in the test.

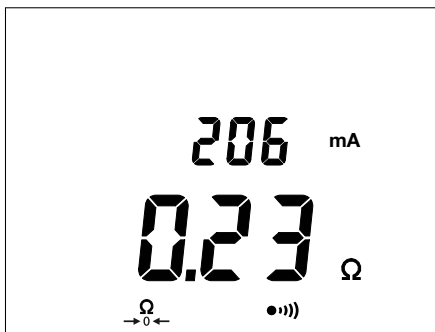

To obtain a continuity value per standard IEC 61557:

1. Take a measurement at 200 mA and note its value R1.
2. Reverse the leads and note the value R2.
3. Calculate the mean: $R = \frac{R_1 + R_2}{2}$

2.2.4 Resistance Measurement

Resistance measurements up to 1000 k Ω are made with a low current.

1. Set the rotary switch to **k Ω** .

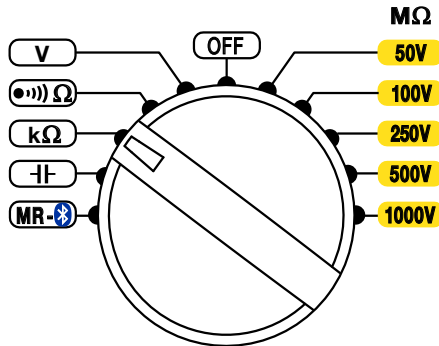

2. Connect the system to be tested to the instrument. The device to be tested must be powered down and discharged.
3. The instrument displays the results.



2.2.5 Capacitance Measurement (Model 6526)

1. Set the rotary switch to **-| |**.

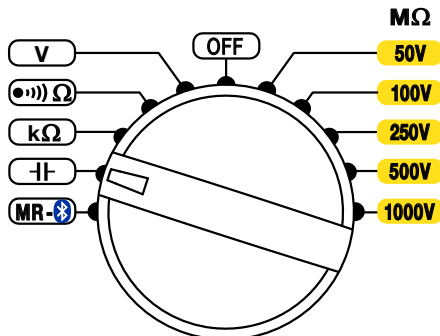

2. Connect the system to be tested to the instrument. The device to be tested must be powered down and discharged.
3. The instrument displays the capacitance.



2.3 RECORDING DATA

2.3.1 Recording a Measurement

A measurement can be stored in the instrument's memory if the measurement is:

- **Frozen** on the LCD via the **HOLD** button (§ 2.1.5)
- The result of a timed test (§ 2.2.2.2)

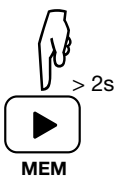

To save the measurement, press the **MEM** button for >2 seconds. The measurement is stored in the first available record in the instrument's memory.

The saved recording includes all information associated with the measurement, including voltage, current, duration of tests, T1 and T2 (for **PI** and **DAR**), and other data. The recording also includes a bar graph indicating how much available memory remains in the instrument.



2.3.2 Viewing Stored Recordings

1. Set the rotary switch to **MR**.

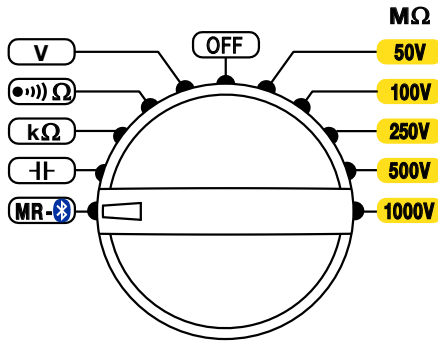

2. The instrument displays the last recording stored in the instrument. The secondary (top) display indicates the memory location; while the main display indicates the measured value.

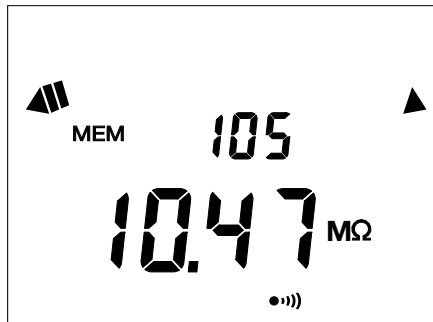

To see the other measurements, press the **▲** button. The record number is decremented and the corresponding measurement is displayed.

3. To scroll rapidly through the recorded measurements, keep the **▲** button pressed.
4. To select a specific recording, use the **▶** button to change the recording number.
5. Once you select the recording number, you can see all information associated with the measurement. Press the **MEM** button for >2 seconds, then use the **▲** button to scroll the information.
6. When finished viewing recordings, press **MEM** for >2 seconds.

2.3.3 Deleting Recordings

2.3.3.1 Deleting a Single Recording

1. Set the rotary switch to **MR**.
2. Use the ▲ and ► buttons to select the number of the recording to be deleted.
3. Press the **CLR** button for >2 seconds. The record number blinks and the LCD displays the letters **CLR**.
4. Press the **MEM** button for >2 seconds to confirm the deletion. To cancel, press the **CLR** button for >2 seconds.

2.3.3.2 Deleting All Records

1. Set the rotary switch to **MR**.
2. Press the **CLR** button for >2 seconds.
3. Press the ▲ button; the record number is replaced by **ALL**.
4. To cancel, press the **CLR** button for >2 seconds. Otherwise, press the **MEM** button for >2 seconds to confirm the deletion.
5. The instrument displays a message indicating the memory is empty.



3. SPECIFICATIONS

3.1 GENERAL REFERENCE CONDITIONS

Quantity of Influence	Reference Values
Temperature	(73.4 ± 5.4) °F (23 ± 3) °C
Relative humidity	(45 to 55) % RH
Frequency	DC and (45 to 65) Hz
Supply voltage	8 V ± 0.2 V battery life indication (58 ± 8) %
Electric field	0 V/m
Magnetic field	<40 A/m

- The intrinsic uncertainty is the error specified for the reference conditions.
- The operating uncertainty includes the intrinsic uncertainty plus variations of the quantities of influence (position, supply voltage, temperature, etc.) as defined in standard IEC 61557.



NOTE: In this section, uncertainties are typically expressed as % of the reading (R) plus number of display counts (ct).

3.2 ELECTRICAL SPECIFICATIONS

3.2.1 Voltage Measurement

Specific reference conditions: Peak factor = 1.414 in AC, sinusoidal signal.

Measurement Range	(0.3 to 399.9) V	(400 to 700) V
Resolution	0.1 V (AC and DC)	1 V (AC and DC)
Accuracy	± (3 % R + 2 ct)	
Input impedance	400 kΩ	
Frequency ranges	DC and 15.3 to 800 Hz	

3.2.2 Frequency Measurement

Measurement Range	(15.3 to 399.9) Hz	(400 to 800) Hz
Resolution	0.1 Hz	1 Hz
Accuracy	± (1 % R + 2 ct)	± (1.5 % R + 1 ct)

3.2.3 Insulation Measurement

Specific reference condition: Capacitance in parallel on resistance = null

Measurement ranges per model

Test Voltage	Model 6526	Model 6534
10 V	-	2 kΩ to 1 GΩ
25 V	-	5 kΩ to 2 GΩ
50 V	10 kΩ to 10 GΩ	-
100 V	20 kΩ to 20 GΩ	20 kΩ to 10 GΩ
250 V	50 kΩ to 50 GΩ	50 kΩ to 25 GΩ
500 V	100 kΩ to 100 GΩ	100 kΩ to 50 GΩ
1000 V	200 kΩ to 200 GΩ	-

Accuracy

Model 6526

Test Voltage (V _T)	50 V - 100 V - 250 V - 500 V - 1000 V					
Measurement range	10 to 999 kΩ and 1.000 to 3.999 MΩ	4.00 to 39.99 MΩ	40.0 to 399.9 MΩ	400 to 3999 MΩ	4.00 to 39.99 GΩ	40.0 to 200.0 GΩ
Resolution	1 kΩ	10 kΩ	100 kΩ	1 MΩ	10 MΩ	100 MΩ
Accuracy	$V_T = 50 \text{ V}: \pm (3 \% R + 2 \text{ ct} + 2 \% / \text{G}\Omega)$ $V_T = 100 \text{ V}: \pm (3 \% R + 2 \text{ ct} + 1 \% / \text{G}\Omega)$ $V_T = 250 \text{ V}: \pm (3 \% R + 2 \text{ ct} + 0.4 \% / \text{G}\Omega)$ $V_T = 500 \text{ V}: \pm (3 \% R + 2 \text{ ct} + 0.2 \% / \text{G}\Omega)$ $V_T = 1000 \text{ V}: \pm (3 \% R + 2 \text{ ct} + 0.1 \% / \text{G}\Omega)$					

Model 6534

Test Voltage (V _T)	10 V - 25 V - 100 V - 250 V - 500 V					
Measurement range	2 to 999 kΩ and 1.000 to 3.999 MΩ	4.00 to 39.99 MΩ	40.0 to 399.9 MΩ	400 to 3999 MΩ	4.00 to 39.99 GΩ	40.0 to 50.0 GΩ
Resolution	1 kΩ	10 kΩ	100 kΩ	1 MΩ	10 MΩ	100 MΩ
Accuracy	$V_T = 10 \text{ V}: \leq 999 \text{ k}\Omega: \pm (4 \% R + 20 \text{ ct}); \geq 1.000 \text{ M}\Omega \pm (3 \% R + 2 \text{ ct} + 1 \% / 100 \text{ M}\Omega)$ $V_T = 25 \text{ V}: \pm (3 \% R + 2 \text{ ct} + 0.4 \% / 100 \text{ M}\Omega)$ $V_T = 100 \text{ V}: \pm (3 \% R + 2 \text{ ct} + 1 \% / \text{G}\Omega)$ $V_T = 250 \text{ V}: \pm (3 \% R + 2 \text{ ct} + 0.4 \% / \text{G}\Omega)$ $V_T = 500 \text{ V}: \pm (3 \% R + 2 \text{ ct} + 0.2 \% / \text{G}\Omega)$					

For all test voltages, when the insulation resistance is $\leq 2 \text{ G}\Omega$ the intrinsic uncertainty is $\pm (3 \% R + 2 \text{ ct})$.

Bar Graph

Measurement Range	0.1 M Ω to 200 G Ω *
Resolution	9 segments per decade
Accuracy	$\pm (5 \% R + 1 \text{ segment})$

*When the measurement range is exceeded, the whole bar graph is displayed.

Test Voltage

Measurement Range	(0.0 to 399.9) V	(400 to 1250) V
Resolution	0.1 V	1 V
Accuracy	$\pm (3 \% R + 3 \text{ ct})$	

Typical discharge time after test

To go from V_T to 25 V, the discharge time is $< 2 \text{ s}/\mu\text{F}$.

Test Current

Maximum test current: 2 mA

Measurement Range	(0.01 to 39.99) μA	(40.0 to 399.9) μA	(0.400 to 2.000) mA
Resolution	10 nA	100 nA	1 μA
Accuracy	$\pm (10 \% R + 3 \text{ ct})$		

Typical Test Voltage vs Load Curve

The voltage as a function of the measured resistance is illustrated below:

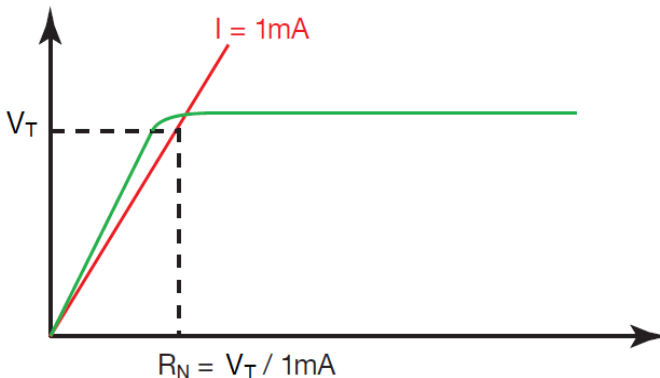

The range of operation per IEC 61557 is from 100 k Ω to 2 G Ω (see § 3.4).

3.2.4 Continuity Measurement

Specific reference condition: Inductance in series with the resistance = zero.

Measurement Range (without compensation of the leads)	(0.00 * to 10.00) Ω	(0.0 * to 100.0) Ω
Resolution	10 m Ω	100 m Ω
Accuracy	$\pm (2 \% + 2 \text{ ct})$	
Test current	200 mA	20 mA
Open voltage	$\geq 6 \text{ V}$	

*In the case of incorrect compensation of the leads, the instrument allows display of negative values, down to -0.05 Ω at 200 mA and -0.5 Ω at 20 mA.

Test Current

200 mA range: 200 mA (0 mA + 20 mA)

20 mA range: 20 mA \pm 5 mA

Measurement Range	(0 to 250) mA
Resolution	1 mA
Accuracy	$\pm (2 \% + 2 \text{ ct})$

Compensation of the leads: 0 to 9.99 Ω .

3.2.5 Resistance Measurement

Measurement Range	(0 to 3999) Ω	(4.00 to 39.99) k Ω	(40.0 to 399.9) k Ω	(400 to 1000) k Ω
Resolution	1 Ω	10 Ω	100 Ω	1k Ω
Accuracy	$\pm (3 \% + 2 \text{ ct})$			
Open voltage	approximately 4.5 V			

3.2.6 Capacitance Measurement (Model 6526)

Capacitance

Measurement Range	(0.1 to 399.9) nF	(400 to 3999) nF	(4.00 to 10.0) μ F
Resolution	0.1 nF	1 nF	10 nF
Accuracy	$\pm (3 \% + 2 \text{ ct})$		

3.2.7 Timer

Measurement Range	0:00 to 39:59
Resolution	1 s
Accuracy	± 1 % of duration

3.2.8 Storage Memory

Maximum number of recordings stored in memory: 1300

3.2.9 Bluetooth

Bluetooth 2.1; Class II; Range 10 m (approximately 33 ft)

3.3 OPERATING ENVIRONMENT

3.3.1 Voltage Measurement

Influencing Parameter	Range of Influence	Quantity Influenced	Influence	
			Typical	Maximum
Temperature	(-4 to 131) °F (20 to + 55) °C	V, F		0.3 % R/18 °F + 1 ct (0.3 % R/10 °C + 1 ct)
Relative humidity	20 to 80 % RH	V, F		1 % R + 2 ct
Frequency	(15.3 to 800) Hz	V	1 %	2 % R + 1 ct
Supply voltage	6.6 to 9.6 V	V, F		0.1 % R + 2 ct
Common mode rejection in AC 50/60 Hz	0 to 600 VAC	V	50 dB	40 dB

3.3.2 Insulation Measurement

Influencing Parameter	Range of Influence	Quantity Influenced	Influence	
			Typical	Maximum
Temperature	(-4 to 131) °F (-20 to + 55) °C	MΩ R ≤ 3 GΩ 3 GΩ < R < 10 GΩ 10 GΩ ≤ R	1 % R/10 °C + 1 pt	2 % R/10 °C + 2 ct 3 % R/10 °C + 2 ct 4 % R/10 °C + 2 ct
		V _T : 50 to 500 V V _T : 1000 V		0.5 % R/10 °C + 1 ct 1 % R/10 °C + 1 ct
		Measurement current	1 % R/10 °C + 1 ct	2 % R/10 °C + 2 ct
Relative humidity	(20 to 80) % RH	MΩ	2 % R + 1 ct	3 % R + 2 ct
		V _T : (50 to 1000) V		1 % R + 2 ct
		Measurement current		1 % R + 2 ct

Influencing Parameter	Range of Influence	Quantity Influenced	Influence	
			Typical	Maximum
Supply voltage	(6.6 to 9.6) V	M Ω		0.1 % R + 2 ct
50/60 Hz AC voltage superposed on the test voltage (V_T)		10 V range R \leq 0.1 G Ω : 10 V from (0.1 to 0.3) G Ω : 0.2 V		5 % R + 2 ct
		25 V range R \leq 0.1 G Ω : 10 V from (0.1 to 0.5) G Ω : 0.2 V		
		50 V range R \leq 0.1 G Ω : 4 V from (0.1 to 1) G Ω : 0.2 V		
		100 V and 250 V ranges from 100 k Ω to 10 M Ω : 20 V from 10 M Ω to 1 G Ω : 0.3 V		
		500 V and 1000 V ranges from 500 k Ω to 50 M Ω : 20 V from 50 M Ω to 3 G Ω : 0.3 V		
Capacitance in parallel on resistance to be measured	(0 to 5) μ F at 1 mA	M Ω		1 % R + 1 ct
	(0 to 2) μ F	10 V and 25 V ranges from 10 k Ω to 1 G Ω	2 % R + 1 ct	3 % R + 2 ct
		50 V, 100 V and 250 V ranges from 10 k Ω to 3 G Ω	6 % R + 2 ct	10 % R + 2 ct
		500 V and 1000 V ranges from 100 k Ω to 10 G Ω	6 % R + 2 ct	10 % R + 2 ct
	(0 to 1) μ F	50 V range, \leq 5 G Ω 250 V range, \leq 15 G Ω 1000V range, \leq 100 G Ω	6 % R + 2 ct	10 % R + 2 ct
Common mode rejection in AC 50/60 Hz	(0 to 600) V _{ac}	V	50 dB	40 dB

3.3.3 Resistance and Continuity Measurement

Influencing Parameter	Range of Influence	Quantity Influenced	Influence	
			Typical	Maximum
Temperature	(-4 to 131) °F (-20 to + 55) °C	at 200 mA		2 % R/10 °C + 2 ct
		at 20 mA		2 % R/10 °C + 2 ct
		R		1 % R/10 °C + 2 ct
Relative humidity	(20 to 80) % RH	at 200 mA		4 % R + 2 ct
		at 20 mA		4 % R + 2 ct
		R		3 % R + 2 ct
Supply voltage	(6.6 to 9.6) V	at 200 mA at 20 mA R		0.1 % R + 2 ct
50/60Hz AC voltage superposed on the test voltage (V_T)	0.5 VAC	at 200 mA		5 % R + 10 ct
	For $R \geq 10 \Omega$: 0.4 VAC	at 20 mA		
	Accepts no perturbations	R		
Common mode rejection in AC 50/60 Hz	(0 to 600) VAC	at 200 mA at 20 mA R	50 dB	40 dB

3.3.4 Capacitance Measurement (Models 6526)

Influencing Parameter	Range of Influence	Quantity Influenced	Influence	
			Typical	Maximum
Temperature	(-4 to 131) °F (-20 to + 55) °C	μF	0.5 % R/10 °C + 1 ct	1 % R/10 °C + 2 ct
Relative humidity	(20 to 80) % RH	μF		1 % R + 2 ct
Supply voltage	(6.6 to 9.6) V	μF		0.1 % R + 2 ct
50/60 Hz AC voltage superposed on the test voltage (V_T)	0.5 VAC	μF		5 % R + 2 ct
Common mode rejection in AC 50/60 Hz	(0 to 600) VAC	μF	50 dB	40 dB

3.4 INTRINSIC UNCERTAINTY AND OPERATING UNCERTAINTY

These megohmmeters comply with standard IEC 61557, which requires that the operating uncertainty (called B) must be less than 30 %.

In insulation and continuity measurements:

$$B = \pm (|A| + 1.15 \sqrt{E_1^2 + E_2^2 + E_3^2})$$

where:

A = intrinsic uncertainty

E₁ = influence of the reference position ± 90 °

E₂ = influence of the supply voltage within the limits indicated by the manufacturer

E₃ = influence of the temperature between (32 and 95) °F (0 and 35) °C

3.5 POWER SUPPLY

The instrument is powered by six 1.5 V alkaline AA (LR6) batteries.

The voltage range ensuring correct operation is from 6.6 V to 9.6 V.

Typical life between charges:

- **Insulation:**

1500 5-second insulation measurements at 1000 V for R = 1 MΩ, at the rate of one measurement per minute

2500 5-second measurements at 500 V for R = 500 kΩ, at the rate of one measurement per minute

6000 5-second measurements at 100 V for R = 100 kΩ, at the rate of one measurement per minute

- **Continuity:** 3000 5-second continuity measurements, at the rate of one measurement per minute

3.6 ENVIRONMENTAL CONDITIONS

Indoor use

Range of operation: (-4 to 131) °F (-20 to +55) °C and (20 to 80) % RH

Range of storage (without batteries): (-22 to 176) °F (-30 to +80) °C and (10 to 90) % RH without condensation

Altitude: <2000 m (6562 ft)

Degree of pollution: 2

3.7 MECHANICAL SPECIFICATIONS

Dimensions (L x W x H): (8.31 x 4.25 x 2.36) in (211 x 108 x 60) mm

Weight: approximately 1.87 lb (850 g)

Ingress protection:

- IP 54 per IEC 60529, not in operation
- IK 04 per IEC 50102

Drop test: per IEC 610

3.8 SAFETY STANDARDS

Safety according to: EN 61010

Insulation Class: 2

Pollution Degree: 2

Overvoltage Category: 600 V CAT IV

Immunity according to: EN 61326

Emission according to: EN 61326

Specifications are subject to change without notice.

4. DATAVIEW® SOFTWARE

AEMC® Instruments DataView® software enables a computer to connect to and interact with a variety of AEMC® instruments, including the Models 6526 and 6534. DataView® includes a core set of features used by all instruments. These features are designed for viewing recorded data; and for opening, creating, and saving DataView® reports. DataView® also includes applications called Control Panels for interacting with the instrument. A Control Panel lets you connect to the instrument, view real-time measurements, download data, and configure the instrument's settings from the computer. Each AEMC® Instruments product family has its own dedicated Control Panel; you select the panel(s) you need during DataView® installation.

4.1 INSTALLING DATAVIEW®

When you purchase the instrument, the product package includes a USB drive containing DataView program files.

To begin installation:

1. Insert the DataView® drive into an available USB port on your computer.
2. If Autorun is enabled, an AutoPlay window appears on your screen. Click **Open folder to view files** to display the DataView folder. If Autorun is not enabled or allowed, use Windows Explorer to locate and open the USB drive labelled **DataView**.
3. When the DataView folder is open, find the file **Setup.exe** in the root directory and double-click it to run the installation program.
4. The Setup screen appears. This enables you to select the language version of the setup program. You can also select additional install options (each option is explained in the Description field). Make your selections and click **Install**.
5. Click **OK** to confirm setup. The InstallShield Wizard screen appears. This program leads you through the DataView® install process. As you complete these screens, be sure to check **Megohmmeter** when prompted to select features to install.
6. When the InstallShield Wizard finishes installing DataView®, the Setup screen appears. Click **Exit** to close. The DataView folder appears on your computer desktop.
7. Open the DataView folder on your desktop. This displays a list of icons for the Control Panel(s) installed with DataView®.
8. Open the DataView® Megohmmeter Control Panel by clicking the  icon.

For more information, consult the DataView® Megohmmeter Control Panel Help.

4.2 MEGOHMMETER CONTROL PANEL

In general, DataView® features are used for creating, viewing, editing, and storing DataView reports; while the Control Panel is used for connecting to, configuring, viewing real-time measurements, running real-time tests, and downloading data from the instrument. For users who interact with a single type of an AEMC® Instruments device, we recommend primarily using the Control Panel.

For further information about DataView® and its capabilities, or for information about using the Megohmmeter Control Panel, consult the Help system that comes with the product.

4.3 CONNECTING TO THE COMPUTER

Before you can use the Megohmmeter Control Panel to communicate with your instrument, you must establish a Bluetooth wireless connection between the instrument and the computer running DataView®.



To begin, ensure that you have installed DataView®, and selected the **Megohmmeter Control Panel** during the installation process (see § 4.1). Also ensure that the required communication and connection drivers are installed on your computer. These drivers are installed as part of the DataView® installation process. Bluetooth must be enabled on the instrument (see § 4.3.1) and your computer. Some computers have Bluetooth connectivity built in, while others require a Bluetooth-USB adapter. When this adapter is plugged into a USB port and configured with the appropriate driver, the computer can communicate via Bluetooth.

To connect the instrument to the computer, you must pair it via Bluetooth (§ 4.3.2) and then use the Control Panel to establish the connection to DataView® (§ 4.3.3).

4.3.1 Enabling Bluetooth on the Instrument

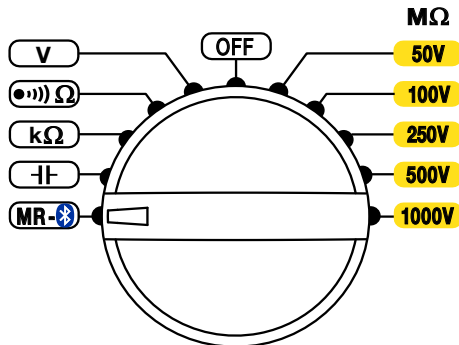
1. Set the rotary switch to **MR** .



2. Press the  button for >2 seconds. The  icon appears on the LCD, indicating Bluetooth is enabled on the instrument.

4.3.2 Pairing the Instrument to the Computer

1. Open the Bluetooth Devices dialog on your computer to pair the instrument with your computer. Different operating systems have different steps for opening this dialog, consult your computer's documentation for instructions.
2. Once the dialog is displayed, click **Add a Device**. A dialog box appears listing the locally available Bluetooth devices. There may be several devices of varying types listed, depending on the location of your computer.
3. Find the instrument's Bluetooth name, and click on that name.
4. You are prompted to enter a pairing code; enter **1111**.
5. After you enter the code, click **Next**. A screen appears informing you that the instrument has been successfully connected with the computer. Click **Close** to exit the screen.



NOTE: To view real-time data in the DataView® Control Panel, the instrument dial must be turned to the appropriate measurement range.

4.3.3 Connecting the Instrument with the Control Panel

When the computer is Bluetooth-ready, you can connect to the instrument as follows:

1. Open the Megohmmeter Control Panel. In the menu bar at the top of the screen, select **Help**. In the drop-down menu that appears, click the option **Help Topics**. This opens the Megohmmeter Control Panel Help system.
2. Use the Contents window in the Help system to locate and open the topic **Connecting to an Instrument**. This topic provides instructions explaining how to connect your instrument to the computer.
3. After the instrument is successfully connected, consult the Control Panel Help system for instructions about viewing real-time data, downloading and viewing recorded sessions, creating DataView® reports from the downloaded data, and configuring the instrument through the Control Panel.

5. MAINTENANCE AND TROUBLESHOOTING



NOTE: Except for the batteries, the instrument contains no parts that can be replaced by personnel who have not been specially trained and accredited. Any unauthorized repair or replacement of a part by an **equivalent** may impair safety.

5.1 MAINTENANCE

5.1.1 Cleaning

- Disconnect the unit completely and turn the rotary switch to OFF.
- Use a soft cloth, dampened with soapy water. Rinse with a damp cloth and dry rapidly with a dry cloth or forced air. Do not use alcohol, solvents, or hydrocarbons.
- Do not use the instrument again until it is completely dry.

5.1.2 Replacing the Batteries

At start-up, the instrument displays the remaining battery life:

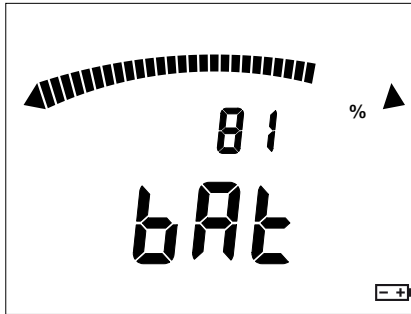

If the battery voltage is too low to ensure correct operation of the instrument, a **low battery** message appears on the LCD and the  symbol blinks:



This indicates the batteries must be replaced. All batteries must be replaced at the same time.

To do this:

1. Disconnect any attached leads or accessories from the instrument and turn the rotary switch to **OFF**.
2. Use a tool or a coin to turn the quarter-turn screw of the battery compartment cover.
3. Remove the battery compartment cover.
4. Remove the batteries from the compartment.

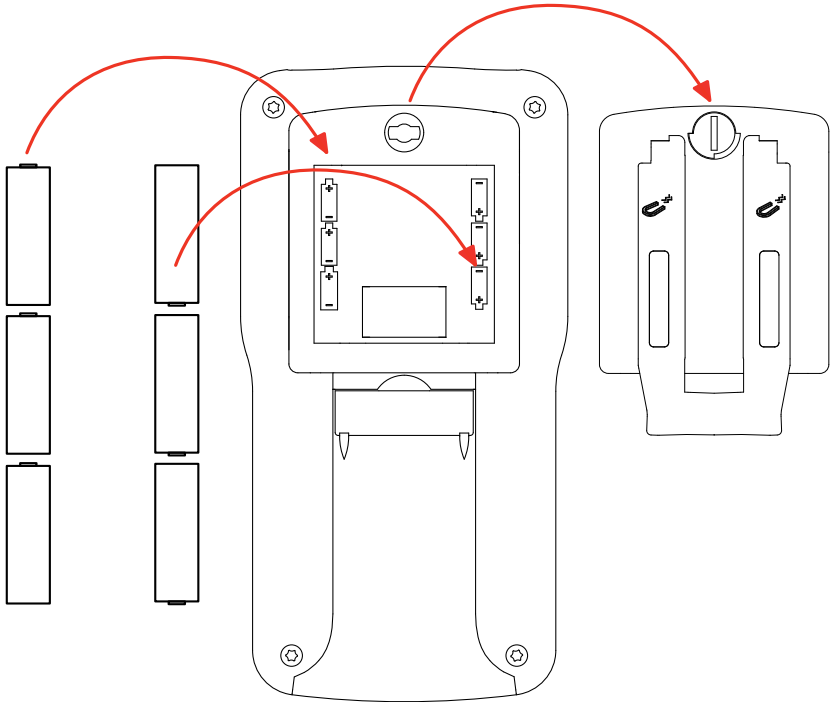

NOTE: Do not treat spent batteries as ordinary household waste. Take them to the appropriate collection facility for recycling.

5. Place the new batteries in the compartment, ensuring that each battery's polarity is correct.
6. Put the battery compartment cover in place and screw the quarter-turn screw back in place.

5.2 TROUBLESHOOTING

5.2.1 Errors

During instrument operation, errors may be displayed on the LCD. The causes of any errors must be corrected before the instrument can resume normal operation.

5.2.1.1 Voltage Present Before an Insulation Measurement

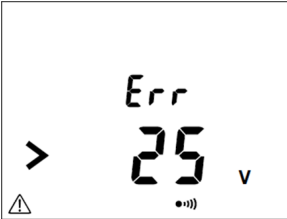

Before taking an insulation measurement, the instrument measures voltage on the system under test. If it detects voltage in excess of 25 V and you attempt to take a measurement, the instrument displays the message shown to the left, and no measurement is taken.

You must eliminate the voltage to resume taking the measurement.

5.2.1.2 Range Exceeded During an Insulation Measurement

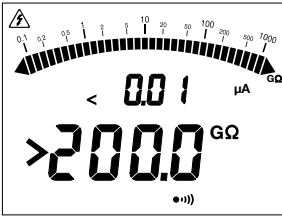

If during an insulation measurement the value to be measured exceeds the measurement range (which depends on the instrument and the test voltage), the instrument reports this condition. For example, the screen to the left is displayed when the range is exceeded while measuring in the 100 V range.



With the Model 6526, if this condition occurs during a **DAR** or **PI** measurement, the instrument interrupts the measurement and displays the screen shown to the left.

5.2.1.3 Voltage Present During a Continuity, Resistance, or Capacitance Measurement (Model 6526)

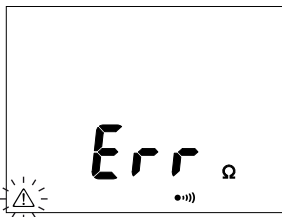

If during a continuity, resistance, or capacitance measurement the instrument detects an external voltage in excess of 15 V (AC or DC), it interrupts the measurement and displays the screen shown to the left.

You must eliminate the voltage to resume the measurement.

5.2.1.4 Memory Full

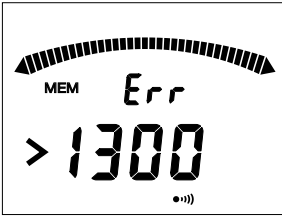

When the memory is full, the instrument displays the screen shown to the left. You must remove one or more recordings before new recordings can be saved (see § 2.3.3).

5.2.2 Resetting the Instrument

You can reset your instrument at any time.

To do this:

1. Press the ▲ and ☼ buttons simultaneously.
2. Turn the rotary switch to any setting other than OFF.
3. The instrument reboots.

5.3 REPAIR AND CALIBRATION

To ensure that your instrument meets factory specifications, we recommend that it be sent back to our factory Service Center at one-year intervals for recalibration or as required by other standards or internal procedures.

For instrument repair and calibration:

You must contact our Service Center for a Customer Service Authorization Number (CSA#). Send an email to repair@aemc.com requesting a CSA#, you will be provided a CSA Form and other required paperwork along with the next steps to complete the request. Then return the instrument along with the signed CSA Form. This will ensure that when your instrument arrives, it will be tracked and processed promptly. Please write the CSA# on the outside of the shipping container. If the instrument is returned for calibration, we need to know if you want a standard calibration or a calibration traceable to N.I.S.T. (includes calibration certificate plus recorded calibration data).

Ship To: Chauvin Arnoux®, Inc. d.b.a. AEMC® Instruments
15 Faraday Drive • Dover, NH 03820 USA
Phone: (800) 945-2362 (Ext. 360) / (603) 749-6434 (Ext. 360)
Fax: (603) 742-2346
E-mail: repair@aemc.com

(Or contact your authorized distributor.)

Contact us for the costs for repair, standard calibration, and calibration traceable to N.I.S.T.



NOTE: You must obtain a CSA# before returning any instrument.

5.4 TECHNICAL ASSISTANCE

If you are experiencing any technical problems or require any assistance with the proper operation or application of your instrument, please call, e-mail or fax our technical support team:

Chauvin Arnoux®, Inc. d.b.a. AEMC® Instruments

Phone: (800) 343-1391 (Ext. 351)

Fax: (603) 742-2346

E-mail: techsupport@aemc.com
www.aemc.com

5.5 LIMITED WARRANTY

The instrument is warranted to the owner for a period of two years from the date of original purchase against defects in manufacture. This limited warranty is given by AEMC® Instruments, not by the distributor from whom it was purchased. This warranty is void if the unit has been tampered with, abused, or if the defect is related to service not performed by AEMC® Instruments.

Full warranty coverage and product registration is available on our website at www.aemc.com/warranty.html.

Please print the online Warranty Coverage Information for your records.

What AEMC® Instruments will do:

If a malfunction occurs within the warranty period, you may return the instrument to us for repair, provided we have your warranty registration information on file or a proof of purchase. AEMC® Instruments will repair or replace the faulty material at our discretion.

REGISTER ONLINE AT: www.aemc.com/warranty.html

5.5.1 Warranty Repairs

What you must do to return an Instrument for Warranty Repair:

First, send an email to repair@aemc.com requesting a Customer Service Authorization Number (CSA#) from our Service Department. You will be provided a CSA Form and other required paperwork along with the next steps to complete the request. Then return the instrument along with the signed CSA Form. Please write the CSA# on the outside of the shipping container. Return the instrument, postage or shipment pre-paid to:

Chauvin Arnoux®, Inc. d.b.a. AEMC® Instruments
15 Faraday Drive, Dover, NH 03820 USA
Phone: (800) 945-2362 (Ext. 360) / (603) 749-6434 (Ext. 360)
Fax: (603) 742-2346
E-mail: repair@aemc.com

Caution: To protect yourself against in-transit loss, we recommend that you insure your returned material.



NOTE: You must obtain a CSA# before returning any instrument.



11/23
99-MAN 100430 v13

AEMC[®] Instruments
15 Faraday Drive • Dover, NH 03820 USA
Phone: (603) 749-6434 • (800) 343-1391 • Fax: (603) 742-2346
www.aemc.com
